

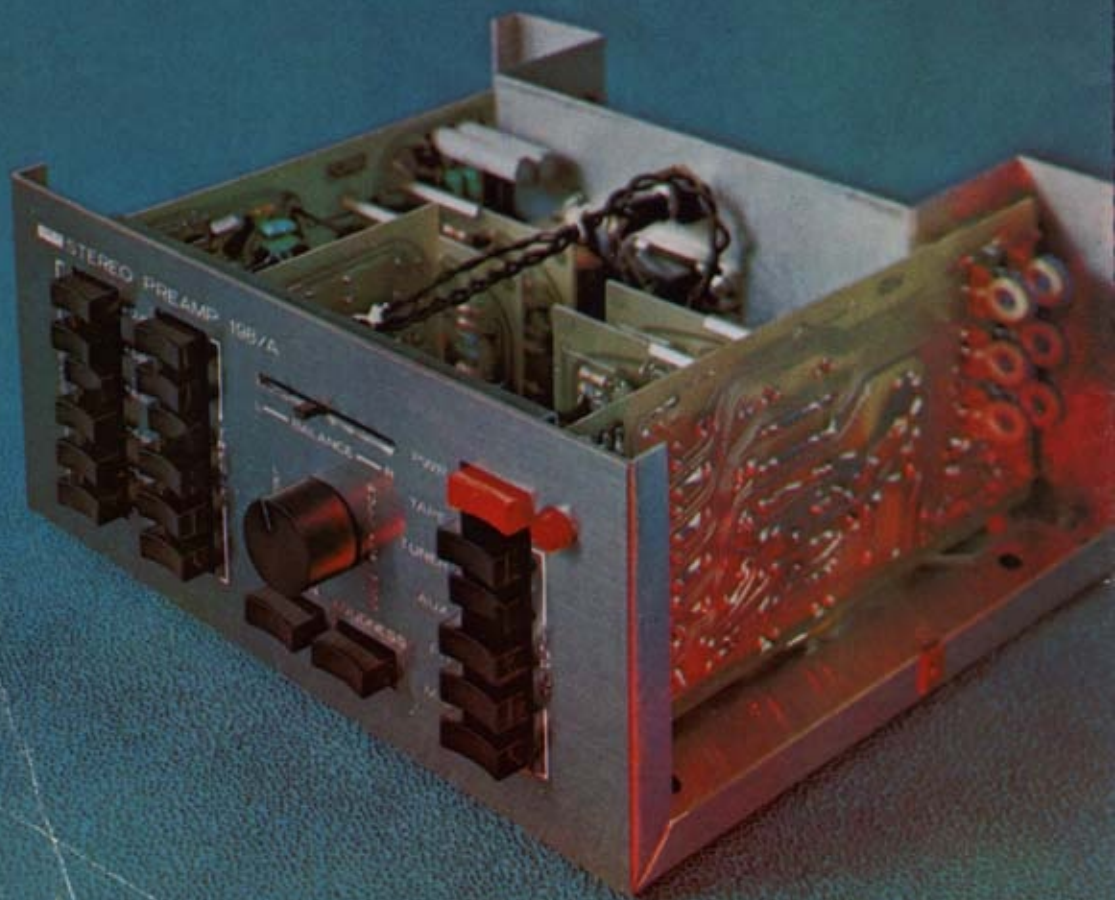

SWT

1975



STEREO PREAMP 1987A

BALANCE

VOLUME

FM
AM
TUNING
ALPHA

POWER
TUNE
ALPHA

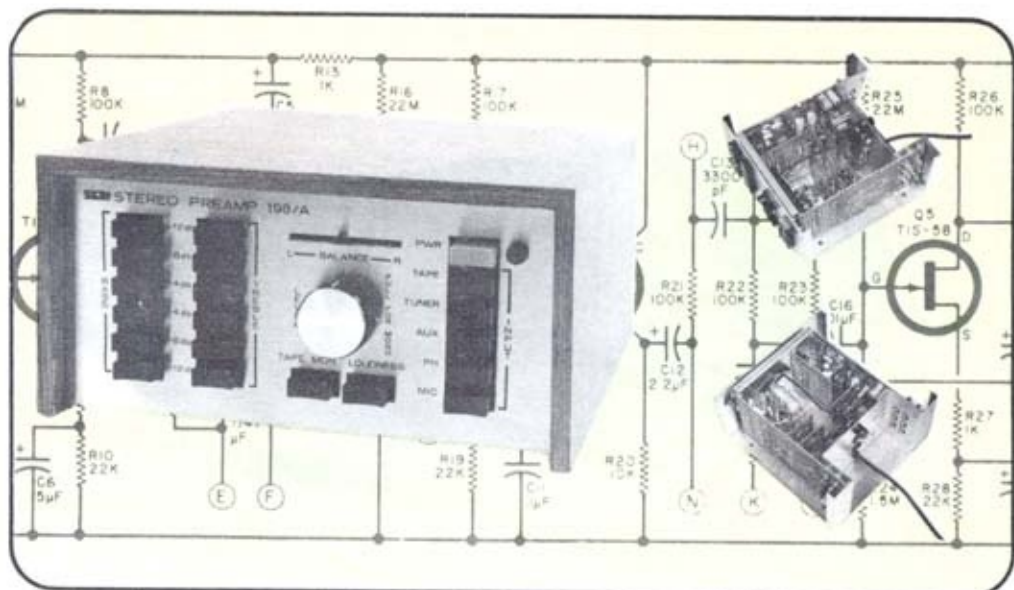

198/A PREAMP

- PUSHBUTTON TONE CONTROLS
- GAIN MODULE DESIGN
- MOTHERBOARD CONSTRUCTION
- SELF POWERED - WILL
- WORK WITH ANY AMPLIFIER

We are proud to offer a preamp and control center that is equal in quality and performance to our new "Tiger .01" amplifier. Both input and tone control settings are push-button switch selected. This makes it possible to get the exact amount of compensation you want every time, just as in

professional studio equipment. When no compensation is wanted the amplification is absolutely flat.

All controls have been designed to make their function as obvious as possible, so that the chances of a mistake in settings will be minimized. Loudness compensation and tape monitor functions are provided.

All gain needed is provided by four of our plug-in #195 opamp circuits. These plug into two "motherboards" that contain all the switching and equalization components. The result is vastly simplified wiring, and easy construction.

The kit is complete with a brushed gold finished front panel and the wood grain finished cover shown. Two switched convenience AC receptacles are provided on the back.

198A Preamp Kit, 6 lbs.....\$74.50 PPd

SPECIFICATIONS

Sensitivity..... Phono and Mic 2.0 mv for 1 Volt output, All Others 100 mv. for 1 Volt output
 Frequency Response..... Flat \pm 1 db 10 to 100,000 Cycles
 Distortion..... Less than .05% Harmonic or IM at rated output
 Noise..... Phono and Mic 65 db down all others 70 db down



Southwest Technical Products Corporation, 219 W. Rhapsody, San Antonio, Texas

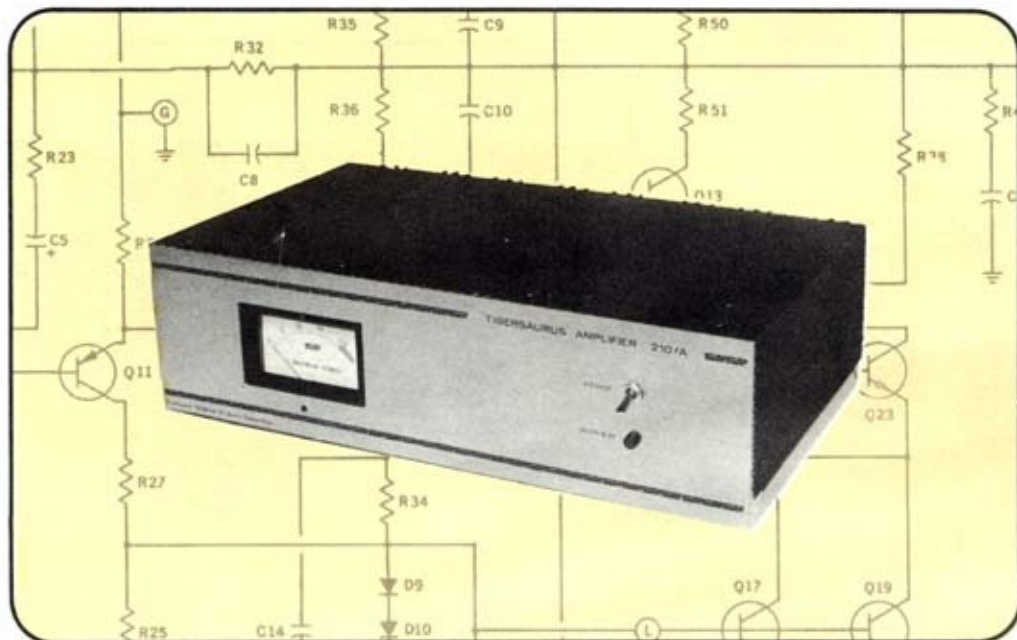

rated output all day, day after day without any overheat problems. No fans, or blower are needed if the case has free air circulation around it.

The circuit features our unique all push-pull system and completely complementary output stage. The driver is the same cross coupled, complementary differential type as used in our famous "Tiger .01". The kit also features a large-three inch lighted output level meter and a robust 25 amp rated rectifier in the power supply. The front trim panel is dusky chrome finished.

For those who are using speakers that can take this kind of power, or for those really big PA jobs this is "THE" amplifier to use.

210 TIGERSAURUS Amplifier Kit
Shipping Weight 28 lbs.\$154.50 PPd

SPECIFICATIONS

250 Watts—4.0 Ohms, or 200 Watts—8 Ohms
minimum sine wave continuous average
power from 20 Hz to 20 kHz with less than
0.1% total harmonic distortion.

IM Distortionless than .03%
Damping factor.....Over 100
Hum and noise -95 dB
Sensitivity2.0 Volts RMS
Size18 wide x 5 high x 11 deep
Shipping Weight24 lbs.

TIGERSAURUS 250

The most powerful amplifier we make for those who want "beastly" amounts of power. We didn't cut any corners, or skimp on any of the parts that went into the design of this animal. The power transformer is a huge 24 pound chunk of iron and copper. The output stage uses eight (8) 200 Watt transistors with a combined rating of 360 Volts @60 Amps. The heat sink for this output stage has over 550 square inches of heavy, efficient extruded aluminum fins. TIGERSAURUS can run at full





TIGER .01

A new standard of performance. We know of no amplifier now available that can match the performance of our new "Tiger .01". Our new completely push-pull circuit with cross coupled push-pull feedback makes possible an IM distortion rating of less than .01% up to rated output. This is easily ten to one hundred times better than many so called Hi-Fi amplifiers. The distortion is so low that presently available instruments cannot accurately measure it. This is the first amplifier that we have ever measured that has lower IM distortion than harmonic distortion. IM distortion is generally recognized as correlating better with listening tests than any other measurement of performance.

The amplifier is designed to be used as either a single channel unit for sound system and

instruments, or in any multiple needed for stereo or quad systems. The front panel is quarter rack size to allow relay rack mounting of up to four of these units in a standard 19 inch relay rack.

The circuit features volt-amp and fuse protection, plus an over heat thermostat. An output meter is provided on the front panel as shown. The perforated metal cover is included in the standard kit.

4 1/4 x 5 x 14

# 207 Complete Kit	
Shipping Weight 15 lbs.....	\$ 77.50 PPd
# 207-A Assembled Amplifier	
Shipping Weight 15 lbs.....	\$105.00 PPd

SPECIFICATIONS

60 Watts—4.0 or 8.0 Ohms minimum sine wave continuous average power from 20 Hz to 20 kHz with less than .05% total harmonic distortion.

IM Distortion.....	less than .01%
Damping factor.....	Over 100
Hum and noise.....	.90 dB
Sensitivity.....	1.0 Volt RMS
Size.....	4 1/4 wide x 5 high x 15 deep
Shipping Weight.....	12 lbs.



Southwest Technical Products Corporation, 219 W. Rhapsody, San Antonio, Texas



The circuit features our outstanding complementary differential input system and current drive to fully complementary output devices. The circuit has volt-amp output protection, speaker fuse, power supply and line fuses. Compare our state of the art circuits to anything else available.

For those who want more features, we offer an accessory kit that allows addition of a front panel switch, overheat indicator and output meter; along with a level control on the rear panel.

UNIVERSAL TIGER "B"

The latest version of our famous "UT" amplifier. We have added our complementary differential input circuit to this rugged old standby and dressed it up in a pretty new box, but otherwise it is still the same all purpose basic amplifier. The "Universal Tiger" is cleaner than the majority of hi-fi amplifiers being offered, but the cost is low enough to use it in PA, organs, background music, and sound system of all types. The 4 1/4 x 5 x 14 package size allows mounting of four of these amplifiers side-by-side in a standard 19 inch relay rack.

The kit has step-by-step instructions, wiring charts and pictorial wiring diagrams. All parts are our usual first quality, standard number parts, made by the world's leading manufacturers. The majority of the construction is on beautiful fibreglass circuits boards.

We think that in "Tiger B" we have one of the most versatile amplifiers made, and the price has to be the bargain of the decade.

# 275 Universal Tiger Amplifier Kit (single channel)	\$ 64.25 PPd
# 2-275 Two of above Kits (for stereo).....	\$125.00 PPd
# AC-275 Accessory Kit (output meter, switch, etc.).....	\$ 7.90 PPd

SPECIFICATIONS

85 Watts—4.0 Ohms, or 70 Watts—8.0 Ohms
minimum sine wave continuous average
power from 20 Hz to 20 kHz with less than
.05% total harmonic distortion.

IM Distortion	less than .03%
Damping factor.....	Over 100
Hum and Noise	-90 dB
Sensitivity	1.0 Volt RMS
Size	4 1/4 wide x 5 high x 15 deep
Shipping Weight	12 lbs.



Southwest Technical Products Corporation, 219 W. Rhapsody, San Antonio, Texas



pictorial wiring diagrams, wiring charts and step by step instructions are provided in the kit.

Compare the specification of this amplifier with any other amplifier offered in this power range. Compare the features, and then compare the prices. Size 4¼ x 4¼ x 13

#215 Stereo Amplifier Kit\$69.50 Ppd

215

Our #215 amplifier is for those who want the superior performance of "Tiger .01", but who do not need, or want 60 Watts per channel. The #215 has the same complementary differential, all push-pull circuit as "Tiger .01" and the same type triple in the output stage. The only difference is in the maximum power output. You get two channels of super clean power in a neat package, with output meters for each channel. The entire circuit, except for the output transistors is built on a plug-in fibreglass circuit board for extra easy construction. The usual

SPECIFICATIONS

25 Watts per channel—4.0 or 8.0 Ohms minimum sine wave continuous average power from 20 Hz to 20 kHz with less than .05% total harmonic distortion.

IM Distortionless than .01%
 Damping factor Over 100
 Hum and Noise......85 dB
 Sensitivity0.75 Volt
 Size 4¾ wide x 4¾ high x 13¾ deep
 Shipping Weight 9 lbs.

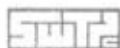

Southwest Technical Products Corporation, 219 W. Rhapsody, San Antonio, Texas

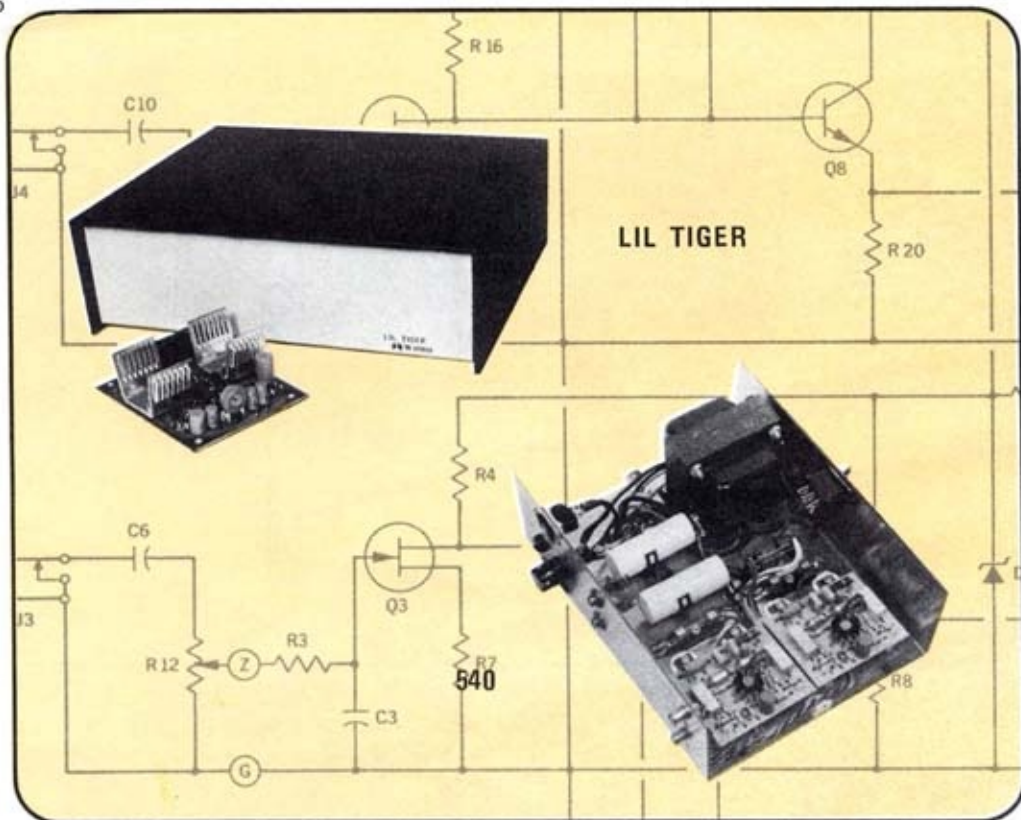

LIL TIGER

15 Watts per channel, minimum sine wave continuous average power from 20 Hz to 20 kHz with less than 0.5% total harmonic distortion.

IM Distortion less than 0.5%
 Hum and Noise -80 dB
 Sensitivity 0.5 Volt
 Size 9½ wide x 3 high x 8 deep
 Shipping Weight 7 lbs.

540

15 Watts per channel, minimum sine wave continuous average power from 20 Hz to 20 kHz with less than 0.5% total harmonic distortion.

IM Distortion less than 0.5%
 Hum and Noise -80 dB
 Sensitivity 0.5 Volt
 Size 9½ wide x 3 high x 8 deep
 Shipping Weight 7 lbs.

In the 20 Watt per channel class we offer you a choice of two amplifiers. For those who have a situation where only a single polarity of supply voltage is available, or who want to build a "classic"; we have Lil Tiger. For those who want the latest design, we have our "540" with IC driver system. Both amplifiers have excellent characteristics and both are packaged in the same chassis with the same power transformer, so the choice of design is yours. Both amplifiers use complementary output transistors and both are constructed on fibreglass circuit boards.

Step-by-step assembly instructions and pictorials make assembly easy enough so that those with only a minimum of electronic experience can easily build these amplifiers.

140 or # 540 amplifier kit (specify) one channel
 Circuit board and parts only
 Shipping Weight 6 oz.....\$11.95 PPd

140 or # 540 Complete Stereo Amplifier (consisting of two of the above kits chassis and power supply)
 Shipping Weight 6.0 lbs.....\$41.25 PPd



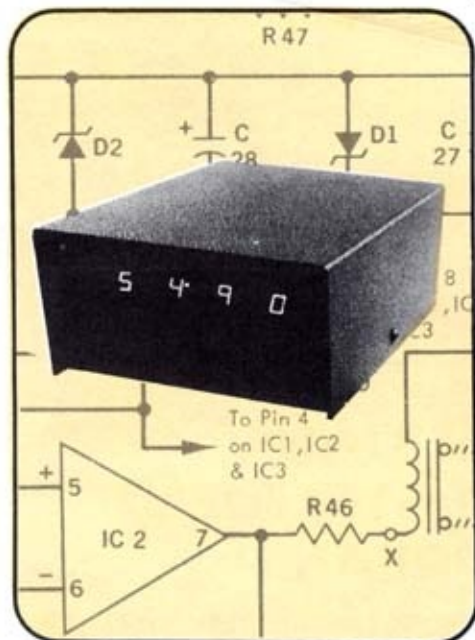
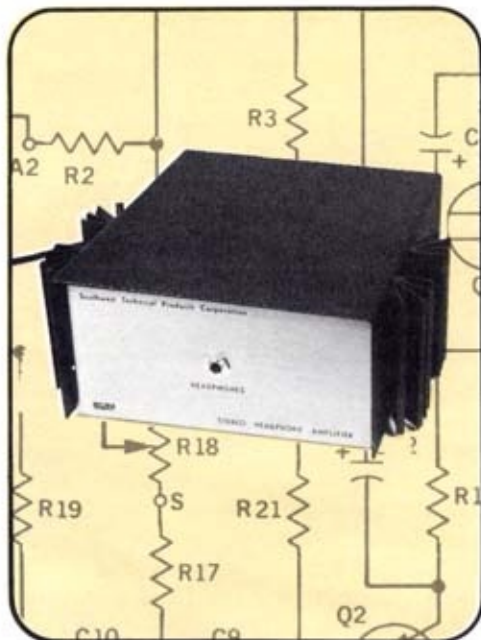

HEADSET AMPLIFIER

DESIGNED SPECIFICALLY TO DRIVE
HEADSETS

CLASS A OPERATION – LOW
DISTORTION AT ANY LEVEL

FLAT + 0.5 DB 10 to 100,000 Hz

At last an amplifier designed specifically for driving a headset. This amplifier has all of the features found in the best power amplifiers, but provides a power output suitable for driving headsets safely. This amplifier will deliver 2 Watts per channel of ultra clean class A power with a damping factor greater than 20 into an 8 - 16 Ohm headset.

Construction is easy. All parts except transformers and connection jacks mount on two of our fiberglass circuit boards. The 7x8x3½ deep case is finished in a beautiful new dusky chrome and has a black vinyl covered steel top.

202-C Headset Amplifier Kit
Shipping Weight 7 lbs.....\$45.75 PPD

DIGITAL TACHOMETER

400 to 9,990 RPM WITH NO RANGE
CHANGING

4 DIGIT LED READOUT

WORKS WITH 4, 6 OR 8 CYLINDER
ENGINES

Our high accuracy digital readout tachometer. This instrument measures your engines RPM ten times a second and displays it on four bright red 0.3 inch high LED readouts.

Only three wire connections in the whole kit. The Tachometer is housed in an attractive black vinyl covered aluminum box 4½ wide by 2½ high by 7 inches deep. May be mounted on top of, or under the dash in your car. Simple hookup - only +12 volts, ground and distributor point connections are needed.

TACH-1 Kit
Shipping Weight 3.0 lbs.....\$59.50 PPD



Southwest Technical Products Corporation, 219 W. Rhapsody, San Antonio, Texas



GUITAR and INSTRUMENT PREAMP

**NEW "NOTCH" TYPE TONE SYSTEM
PLUS - SUPER CLEAN TREMOLO
AND - REVERBERATION
GIVES YOU THE ULTIMATE IN
FLEXIBILITY AND SOUND VARIATION**

Our guitar and instrument preamp combines the latest in tone controls "the notch system" with active filter design to give you the ultimate in flexibility. The use of a rejection notch is the latest thing in creating new sounds. It allows you to greatly reduce, or eliminate the fundamental note from your strings and only allow the harmonics and overtones to be heard. Our system is the only one available anywhere that gives you complete control of the amount, width and depth of the notch. In addition to this you get the usual bass and treble tone controls that allow you to cut, or boost these frequencies. As if this wasn't enough, we have also added an "Emphasis" control that allows you to completely eliminate the bass, or treble frequencies; or mix them together in any proportion desired. You can imagine the versatility you would have with this type control system. Here at last is a single front end that can be used for almost any instrument. It is ideal for a bass, but also has the features you need for a lead instrument.

The "Tremolo" speed can be varied from three to fifteen cycles per second and the depth controlled from zero to one-hundred percent. The tremolo system is very smooth and clean and introduces no sounds of its own. The modulation system used is unique in that it is not just a loss type circuit. It both adds and subtracts from the normal volume level so that the sound output does not drop when tremolo is introduced.

The "Reverb" system uses a high quality spring reverberation unit with a high drive circuit for lots of clean good sounding reverb.

The sound quality of this preamp is comparable to the best stereo systems. Total harmonic distortion typically is less than 0.1% and the bandwidth of the circuits is 10 Hz to 100,000 Hz.

The #211 circuits are powered by an internal AC supply requiring only 110-120 Volts AC at 0.25 Amps. The preamp will drive almost any power amplifier, or PA sound system. The maximum output is over 5 Volts RMS into a 10K Ohm load. This is more than sufficient for any of our power amplifiers and enough for any that we have ever heard about. You are free to use as small, or as large a power amplifier system as necessary for the occasion.

Our preamp is housed in a black vinyl covered wooded cabinet with handsome silver trim and a convenient carrying strap. The cabinet is finished and ready for the electronic portion of the kit. No cabinet assembly is required. 25" x 6 1/2" x 7 1/2" deep

211 Guitar and Instrument Preamp Kit
Shipping Weight 7 lbs. \$96.50 PPd



Southwest Technical Products Corporation, 219 W. Rhapsody, San Antonio, Texas

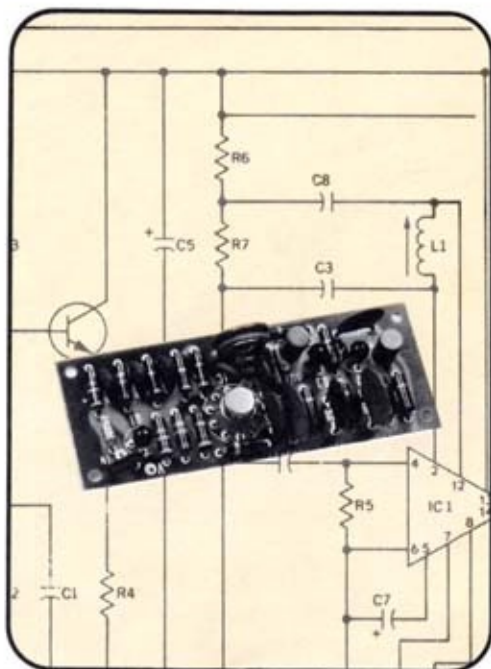

SCA MULTIPLEX ADAPTOR

Now get "Music Only" FM Programs

Sensational new approach to detection of the multiplexed subcarrier used by many FM stations. This adaptor may be used with any FM radio or tuner. New "phaselocked loop" integrated circuit provides both the filtering and FM detector needed to receive these broadcasts. Our kit is complete with instructions for installing the adaptor in your tuner. Power required is 12.0 Volts DC @ 5 Ma.

Use of the "phase locked loop" system results in a circuit with superior rejection of unwanted interfering signals, better fidelity and requires no inductors, or tuned circuits.

Note - Commercial use of this circuit for background music systems is illegal.

# PLL - 1 Shipping Weight 2 lbs.....	\$14.50 PPd
Now available with built-in squelch circuit to eliminate noise if your station drops its SCA carrier.	
# PLLS - Shipping Weight 2 lbs.	\$19.50 PPd
# PLLAS - Assembled	
Shipping Weight 2 lbs.....	\$29.95 PPd

SPECIFICATIONS

Input Impedance5 Meg. Ohms
Output Level	1.0 Volt
Detection Range	50-80 KHz

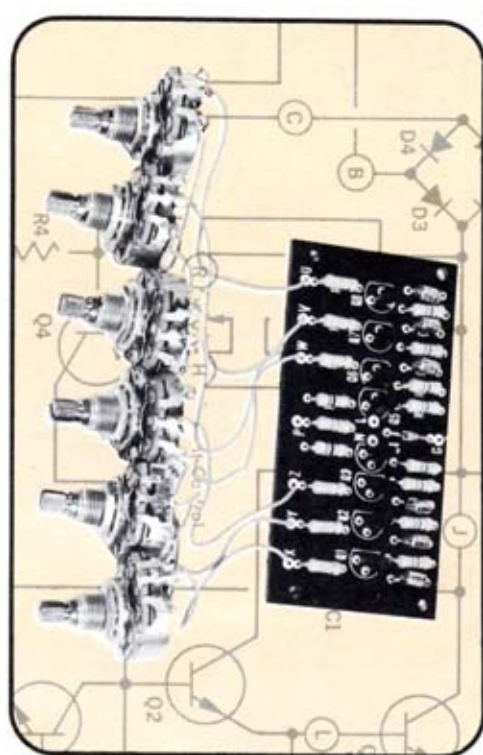

6 INPUT MIXER

For those custom PA designs - Two channels with three inputs on each channel, or six inputs to one channel as needed. An individual FET high impedance input stage is used with individual volume controls for each input. The mixer cannot cause loading, or add noise to your system. Inputs of up to 0.5 Volts RMS may be used without overloading. Circuit gain of 3 in two channel, or unity if used on one channel allows addition of the mixer at almost any point in your system from the microphone to the power amplifier. Requires 12 to 24 Volts DC at 5 Ma. Complete with controls.

1xr-6 Kit - Shipping Weight 1 lb.....	\$13.75 PPd
---------------------------------------	-------------



Southwest Technical Products Corporation, 219 W. Rhapsody, San Antonio, Texas

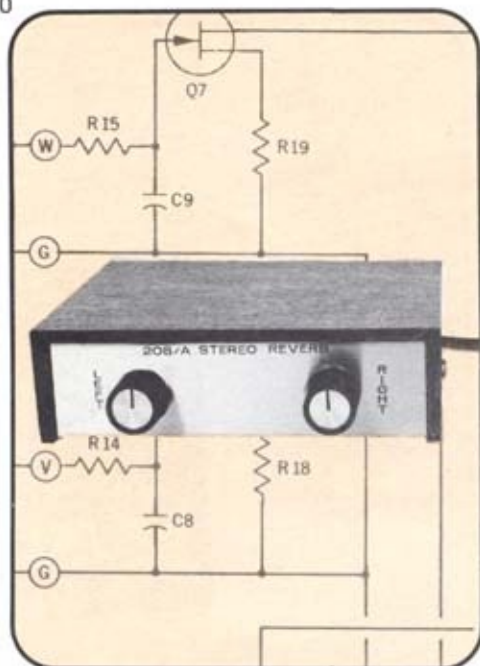

REVERB ADAPTOR

Use our new self powered stereo reverb adaptor to put reverberation into your system. The spring reverb unit adds the "Concert hall" reverberation time to your music electronically. Simulates the acoustics of a large hall and gives your music more "life."

Two independent channels with separate controls to add the exact amount of reverb you prefer in each stereo channel. This self-powered unit is connected between your preamp and power amplifier and may be used with any type system.

Brushed gold chassis with wood grain cover. Step-by-step instruction and use of three integrated circuits make this kit quick and easy to assemble.

239-C Complete Kit with two spring units
Shipping Weight 5½ lbs.\$39.50 PPd
Z-1C Reverb Springs only as used in above kit.
2,000 Ohm input and output.
Shipping Weight 2.0 lbs.each \$10.75 PPd

SPECIFICATIONS

Nominal Delay 37 Milliseconds
Reverberation 0.50%-Control on panel
Size 5 x 5 x ¼

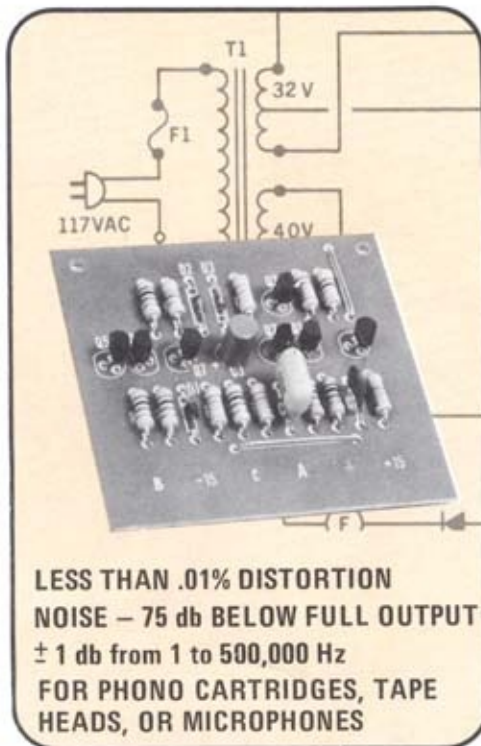

LESS THAN .01% DISTORTION
NOISE - 75 db BELOW FULL OUTPUT
± 1 db from 1 to 500,000 Hz
FOR PHONO CARTRIDGES, TAPE HEADS, OR MICROPHONES

195 PREAMP

We are happy to be able to offer a really outstanding preamp module for those who enjoy building up their own systems. The # 195 preamp is designed using integrated circuit techniques, but by using discrete components much better characteristics are obtained. It is impossible to get really superior noise figures in an IC preamplifier due to the processing steps that are required, each of which tends to add noise. It is also impossible to get precise resistor values and difficult to make both NPN and PNP transistors on the same chip. Our seven transistor circuit is a basic op-amp type system. You add the equalization needed for your application, just as you would with an IC' op-amp module. The 3 x 3 fiberglass circuit board is designed so that it may be wired, or plugged into PC edge connectors. Distortion is less than .01% at any audio frequency. Suggested power supply is ± 15 Volts DC @ 10 Ma, which may be obtained from any of our power amplifiers except # 140. Separate supply available.

195 Preamp Kit
Shipping Weight 8 oz.\$ 8.75 PPd

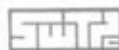

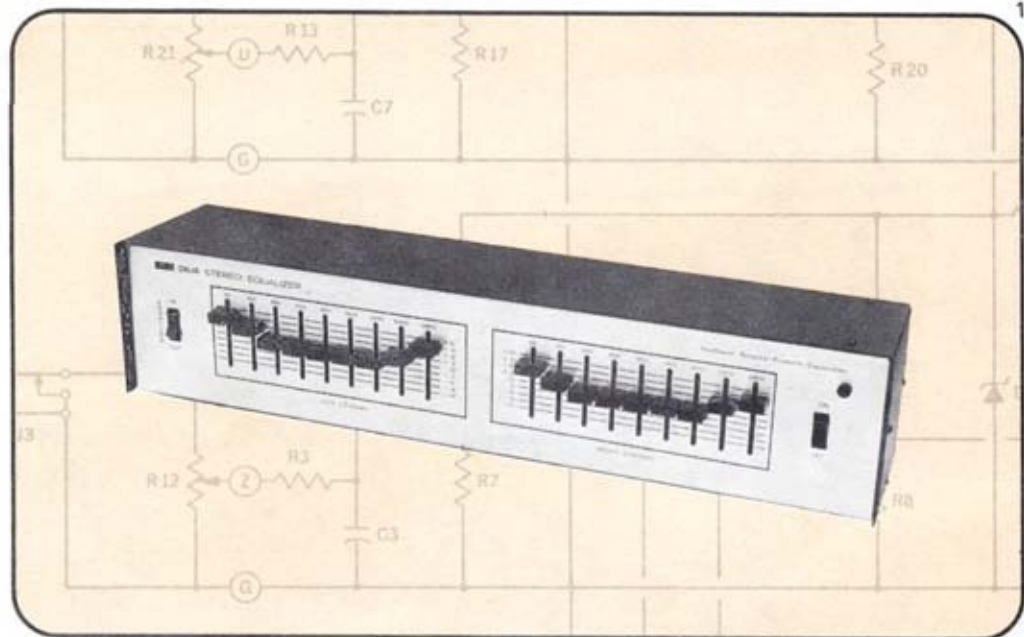

AT LAST

STEREO OCTAVE EQUALIZER

- * NINE INDEPENDENT CONTROLS PER CHANNEL
- * ONE OCTAVE RESPONSE PER CONTROL
- * UP TO ± 12 dB CORRECTION

The one everyone has been asking for. Our octave equalizer is finally ready. It may have taken a while, but we wanted to be able to offer an equalizer that was not only outstanding in performance, but one that was also reasonable in cost.

As shown in the photograph our equalizer has nine (9) independent single octave controls per channel. Each control can either boost or cut frequencies in that particular octave up to ± 12 dB. Controls for each channel are separate, so the equalizer can be used to

adjust each speaker exactly correct with no compromises due to ganged controls for the two channels.

The filter circuits use operational amplifier active filters. There are no inductors to pick up hum or cause ringing problems. This equalizer can be added to your system between the preamp and amplifier, or it can be connected into the tape monitor system of your preamp.

In the flat position, the frequency response is ± 1.0 dB from 5 Hz to 50 KHz. Distortion is typically less than 0.1%. An octave equalizer is the ideal way of compensating for room response. It also makes it possible to compensate for small recording problems that only a narrow band filter could correct. You can bring up weak mid bass, eliminate presence peaks, etc. without affecting the rest of the music.

Our equalizer comes in an all metal enclosure with a black vinyl covered top. The front panel is satin red-gold finished. The circuit is self powered from its own internal power supply. 110-120 Volts AC 50-60 Cycles.

EQ-1 Octave Equalizer Kit\$99.50



Southwest Technical Products Corporation, 219 W. Rhapsody, San Antonio, Texas



CT-1024 TERMINAL SYSTEM

Now everyone can afford a terminal system. Our new CT-1024 is the first TV compatible terminal kit to be offered anywhere. By simply adding a keyboard or any other ASCII coded input and a TV set you have a display system. From this point you can add our CT-S, or CT-L interfaces and you have a time share, or direct access computer terminal.

This device has uses anywhere data needed to be displayed. Advertising displays, teaching aids, deaf communicator are just a few of the many possible applications. The low cost of this kit makes a video display terminal practical in many places that it could not be considered previously.

Our KBD-2 keyboard is shown with the CT-1024 in the photograph. You can write

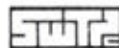

Southwest Technical Products Corporation, 219 W. Rhapsody, San Antonio, Texas

16 lines per page (frame) and each line can have up to 32 characters. A two page memory is standard with this kit—not an extra cost option. A modern static semiconductor memory is used that requires no complicated refresh cycles, or power down operation.

The output of the CT-1024 is a standard video signal that may be used with any monitor, or other TV set having a video input jack. This can easily be added to sets not having this feature. Instructions included in kit.

SPECIFICATIONS

- 1024 Characters memory storage capacity**
- Format—16 lines of up to 32 characters per page.**
- Output—2.25 Volt Video pulse**
- 1.0 Volt Sync pulse**
- Compatible with video input or monitor**
- Input —7 Bit parallel ASCII positive logic**
- Keypress Strobe—positive or negative going**
- Controls—Page Select**
- Erase Page**
- Home Up**
- Power Required +5 Volts DC @ 2.0 Amps**
- 12 Volts DC @ 20 Ma.**
- 5 Volt DC @ 15 Ma.**
- #CT-1024 Terminal System Kit\$175.00 ppd**
- with memory—less cabinet and power supply**

MANUAL CURSOR CONTROL

This plug-in accessory card for the CT-1024 system provides you with several handy cursor control features that are not available in the standard system. In addition to "Home Up" and "Erase" you now have complete motion control. This circuit makes possible "Up", "Down", "Left" and "Right", plus "Erase to End of Frame". Operation may be by any type of pushbutton switch, or key-switch.

#CT-M Manual Cursor Control Kit \$11.50

SCREEN READ CARD

In many applications it is very handy to be able to compose and edit a message on the display screen and then when completed, to transmit the information. This is known as "Screen Read", or "Off Line Edit". This option is almost essential in applications such as RTTY and very handy in many others. Not only does this circuit allow you to edit and check material before it is used, it also allows you to read only the portion you have identified with "!" marks at the beginning and end. You can have comments and notes in the material and they will be ignored by the terminal when it transmits.

#CT-E Screen Read Card Kit \$17.50

DISPLAY POWER SUPPLY

Power supply for the basic CT-1024 terminal system. Provides the +5 Volts, -5 Volts and -12 Volts needed to operate the CT-1024 kit.

#CT-P Power Supply Kit \$15.50

SERIAL INTERFACE (UART)

In uses such as remote time share system, using a modem and a phone line, radio teletype, and other such cases; data must be transmitted in a serial form. This circuit takes the parallel ASCII code from the memory of the CT-1024, and converts it to a serial form that can be transmitted. The standard transmission rate supplied in the kit is 110 Baud, but optional rates of 220, 300, 600 and 1200 Baud are available if you wish to add the parts to the board.

#CT-S Serial Interface Kit \$39.95

PARALLEL INTERFACE

If the CT-1024 is to be connected directly to a computer, then a parallel ASCII input system is generally needed. The parallel interface card has the necessary tri-state buffers and other circuit to allow the terminal to operate properly with any computer using ASCII eight bit code. You also have the option of using full, or half duplex operation.

#CT-L Parallel Interface Kit \$22.95



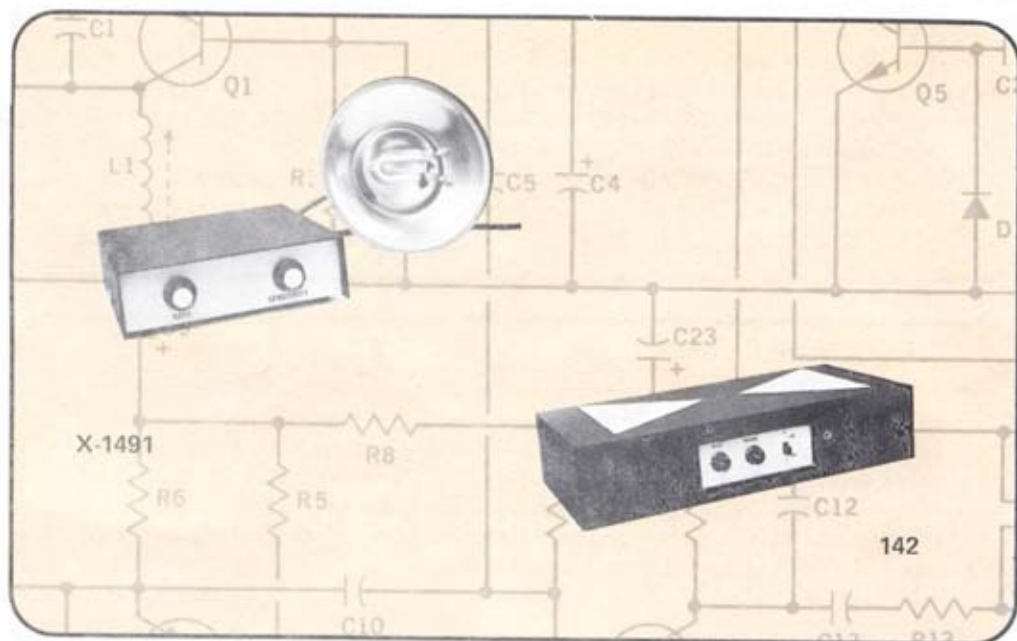

PSYCHEDELIC STROBE LIGHT

One of our most popular electronic kits, the Strobe Light, will delight adults as well as the "teen-scene". Aside from practical uses in photography and general purpose stop-motion observation, this psychedelic strobe light can create the most unusual effects seen with musical groups or "at home" parties. The strobe flashing at a proper rate synchronized with the music in a semi-darkened room produces an illusory and bizarre scene. It reminds one of the old time "flicks" and "The Keystone Kops". Musical groups need not limit their purchase to just one strobe. Experiment with several - The effect is incredible.

The punched cabinet is chrome plated. Top covering is textured black vinyl. Cabinet matches Sonolite Color organ. Polished 5½" reflector.

X-149C Psychedelic Strobe Kit.
Shipping Weight 2 lbs.\$17.50 PPd

THEREMIN ELECTRONIC MUSICAL INSTRUMENT

A modern, solid state version of the Theremin all electronic musical instrument. Two antenna plates, operated by hand capacity, control the pitch and volume of the sound. Add this to your combo for a really unique and different sound.

Our revised version of this instrument now has fully shielded coils and a new tuning circuit. Adjustments are fast and noncritical. The rugged vinyl covered cabinet matches our MMM Instrument amplifier.

#142 Complete kit for Theremin - with cabinet & Antenna
Shipping Weight 4 lbs.\$22.75 PPd

SPECIFICATIONS

Controls Pitch - Zero set - Volume
Approximate Sound Range..... 30 to 15,000 Cycles
Volume Range 50 to 60 db Change
Power Internal 9 Volt Battery



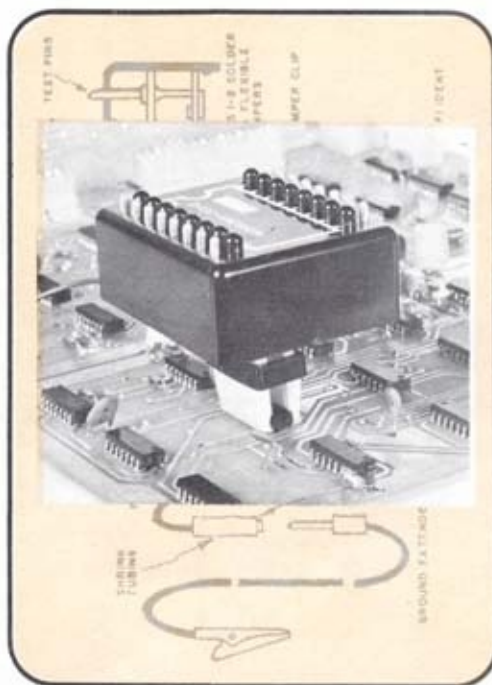

DIGI-VIEWER II

IN-CIRCUIT IC TESTER

CHECKS STATIC AND
DYNAMIC OPERATION

COMPACT—CIRCUIT POWERED

FAST LONG LIFE LED INDICATORS

In-circuit testing of digital IC's is now easier than ever with our new VU-II. This neat compact little instrument features LED indicators, automatic power connection, test points for each pin and a positive locking clip. No where else can you get a tester of this type with all of these features. The LED lamps show at a glance the logic state of each pin on the circuit being checked. The fast response of the LED indicator lamps makes it possible to also check high frequency dynamic response. The special locking type test clip insures safe—no slip—testing of the pack. Convenient test pins on the top of the case make symultaneous scope testing easy and safe.

#VU-II Kit—as illustrated..... \$19.50 PPd



PHONE SENTRY

AUTOMATIC TELEPHONE ANSWERING

Now you'll have no more missed phone calls with the Phone Sentry on the job. This electronic control unit used with two unmodified cassette tape recorders will give you the convenience of automatic telephone answering at a very low price.

When you are not home, the Phone Sentry will respond to the ring signal by playing a message from one of the recorders explaining that you are not home and then allowing 30 seconds for the person calling to give a message.

The Phone Sentry circuits are powered by four internal "C" cells and the only connections needed are to the recorders and the telephone line.

PHS Phone Sentry Kit

Shipping Weight 3 lbs.....\$29.95 PPd



Southwest Technical Products Corporation, 219 W. Rhapsody, San Antonio, Texas

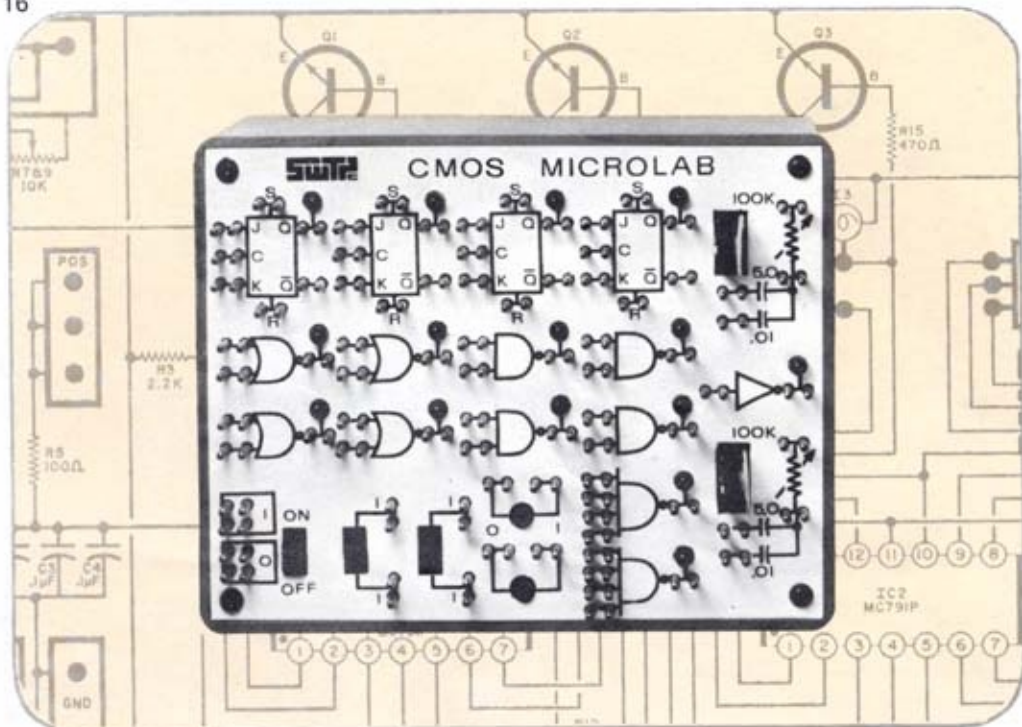

CMOS MICROLAB

- * LEARN HOW DIGITAL CIRCUITS WORK
- * VERIFY DESIGNS QUICKLY
- * IDEAL TEACHING AID
- * PORTABLE—BATTERY OPERATED

The CMOS Microlab makes it possible to quickly check, or understand a variety of digital circuits. Battery operation makes the Microlab super convenient. Use it anywhere. Indicator lamps are all LED types that are rugged and will never burn out. Included in the Microlab are four (4) flip-flops four (4) dual input NOR gates, four (4) dual input NAND gates, two (2) four input NAND gate

and an inverter. Two adjustable RC networks make possible construction of "on board" rate clocks for use with the various circuits that can be constructed. No external signal sources are needed in most cases. Two slide and two pushbutton switches are provided for manual toggling of the circuits. Connections are made with reliable, easy to use push-on type connectors on the jumper wires. The entire instrument is "goof proof" No possible combination of connections, no matter how wrong, can damage the circuit.

The kit is housed in a 5 x 7 x 3 break resistant impact plastic case. Powered by four (4) standard "D" cells. (Not included in kit)

We stock Don Lancasters "TTL Cookbook" which is a good companion book for this kit. It presents basic digital logic in an easy to understand nonmathematical manner. With this book and the Microlab you can have a good understanding of digital circuits in a very short time.

CMOS Complete Microlab Kit
Shipping Weight 4 lbs.....\$34.50 Ppd
"TTL Cookbook"
by D. Lancaster.....\$ 8.00 Ppd



Southwest Technical Products Corporation, 219 W. Rhapsody, San Antonio, Texas



KEYBOARD and ENCODER

- * FULLY PROFESSIONAL SYSTEM
- * 53 KEYS
- * INCLUDES ASCII ENCODER

FOR:

Terminals
Calculators
TV Typewriters
RTTY Displays
Video Displays
Deaf Communicators
Video Titlers
Teaching Aides

At last here is a top quality fully professional keyboard at a reasonable price. A full 53 key system with internal ASCII encoder and switch debouncing. The keys are full typewriter travel gold plated contact type and have smooth durable, double shot molded keytops; just like the ones on typewriters.

Full length spacebar with equalizer mechanism. The output is a standard parallel ASCII code at TTL logic levels, that can be used with almost any type computer system.

Keys and encoder are mounted on a 10 3/4 x 5 7/8 epoxy fibreglass circuit board. The assembled keyboard is approximately 1 1/2 inches high.

KBD-2

Teletype style keyboard and encoder. Provides capital letters and machine commands for; Shift, Control, Line Feed, Escape and Cancel. Combination of IC, transistor and diodes for maximum economy. Two user defined keys with individual output connections.

KBD-2 Keyboard and Encoder Kit.....\$39.95 Ppd

KBD-3

Typewriter style keyboard with LSI one chip MOS encoder. Provides choice of either upper and lower case letters, or just upper case. Machine commands for Return, Escape, Erase, Repeat, Shift and Control; plus two user defined keys.

KBD-3 Keyboard and Encoder Kit.....\$49.95 Ppd

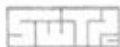

Southwest Technical Products Corporation, 219 W. Rhapsody, San Antonio, Texas

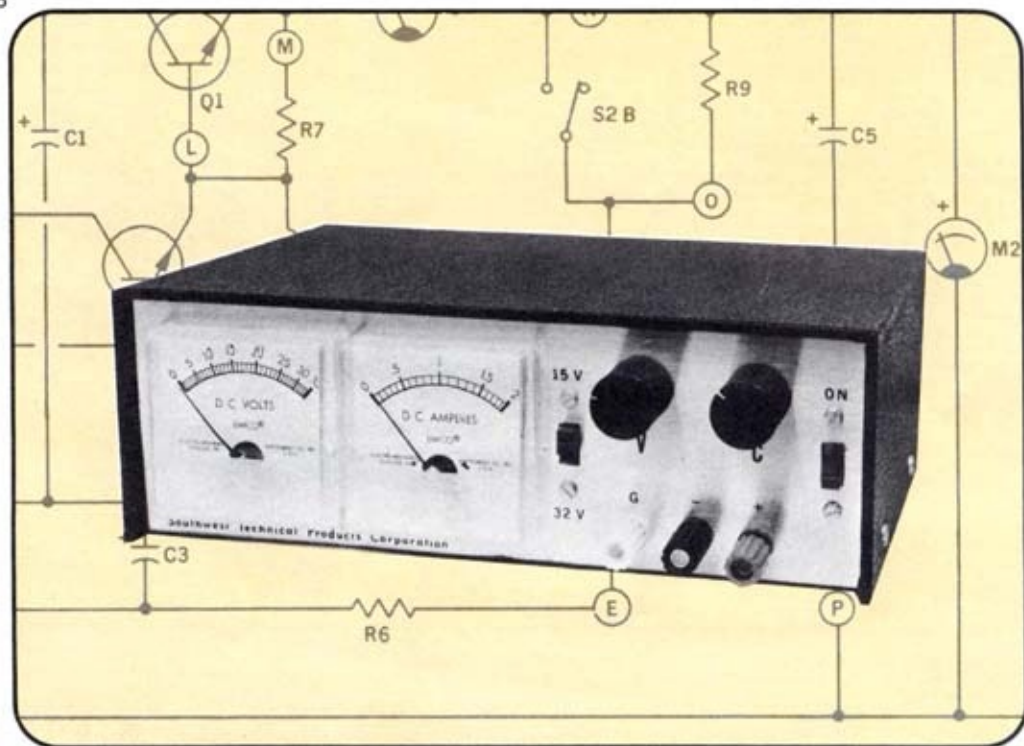

SHORT PROOF POWER SUPPLIES

SINGLE POLARITY

0 ± 35 VOLTS DC 0-2 AMPS

High capacity 0-2 Amp power supply for use where only a single polarity power supply is needed. May be used for either positive, or negative ground circuits. Voltage is adjustable from 0 to 15 and from 15 to 35 Volts. Current limiting is adjustable from 10 Ma. to 2.0 Amps.

Cabinet is all metal with a vinyl covered top, and a brushed gold front panel.

143 Power Supply Kit
Shipping Weight 8.0 lbs.\$41.75 PPd

SPECIFICATIONS

Regulation.....1% or 0.1 Volt for
100% load change
Ripple.....0.3% or 10 Mv. Maximum
Voltage Range.....0-15 and 15-35 Volts DC
Input.....110 to 125 Volts AC

DUAL POLARITY

0 TO ± 20 VOLTS DC 0-1 AMP

The ideal power supply for operational amplifier circuits and any others requiring a split polarity power supply voltage. The voltage control changes both the positive and negative output voltage by equal amounts when adjusted. Current limiting range is 50 Ma. to 1.0 Amp.

Cabinet is same as single polarity type.

243 Power Supply Kit
Shipping Weight 8.0 lbs.\$41.75 PPd

SPECIFICATIONS

Regulation.....0.5% or 0.1 Volt for
100% load change
Ripple.....0.2% or 5 Mv. Maximum
Voltage Range.....0 to ± 20 Volts DC
Input.....110 to 125 Volts AC



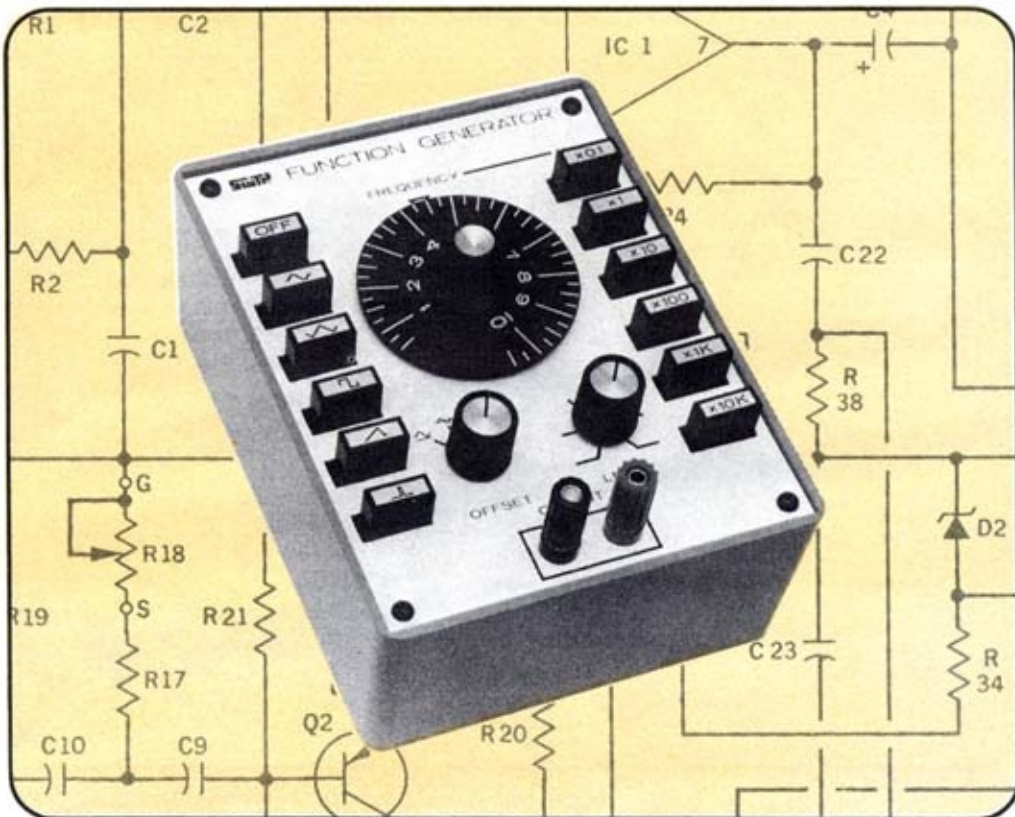

FUNCTION GENERATOR

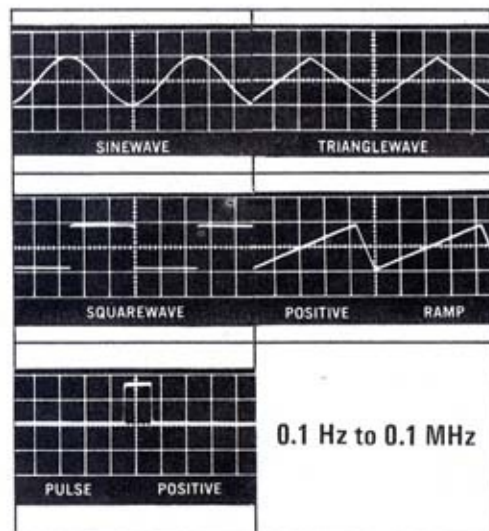

Now, thanks to IC technology, everyone can afford one of these versatile waveform generators. This is the ideal general purpose signal generator. Use it for checking audio equipment, digital circuits, sweep circuits, or anywhere you need a variety of waveforms.

Construction is very simple due to extensive use of circuit boards. Only the offset, level and frequency controls are wired. Our kit features switch selection of waveform, frequency range and type of offset. Output amplitude is constant to less than ± 1 dB on any range and with any waveform. Sine wave distortion is less than 1% from 20 to 20,000 cycles. Square wave and pulse rise times are less than 0.25 microsecond. Accuracy is 1% on the range calibrated and better than 5% on all other ranges.

The Instrument is housed in an impact plastic case for maximum drop protection. Case size $5\frac{1}{4} \times 6\frac{1}{2} \times 2\frac{1}{2}$. Power required 115 Volts AC.

FG-2 Function Generator Kit
Shipping Weight 3 lbs.\$39.95 Ppd



Southwest Technical Products Corporation, 219 W. Rhapsody, San Antonio, Texas

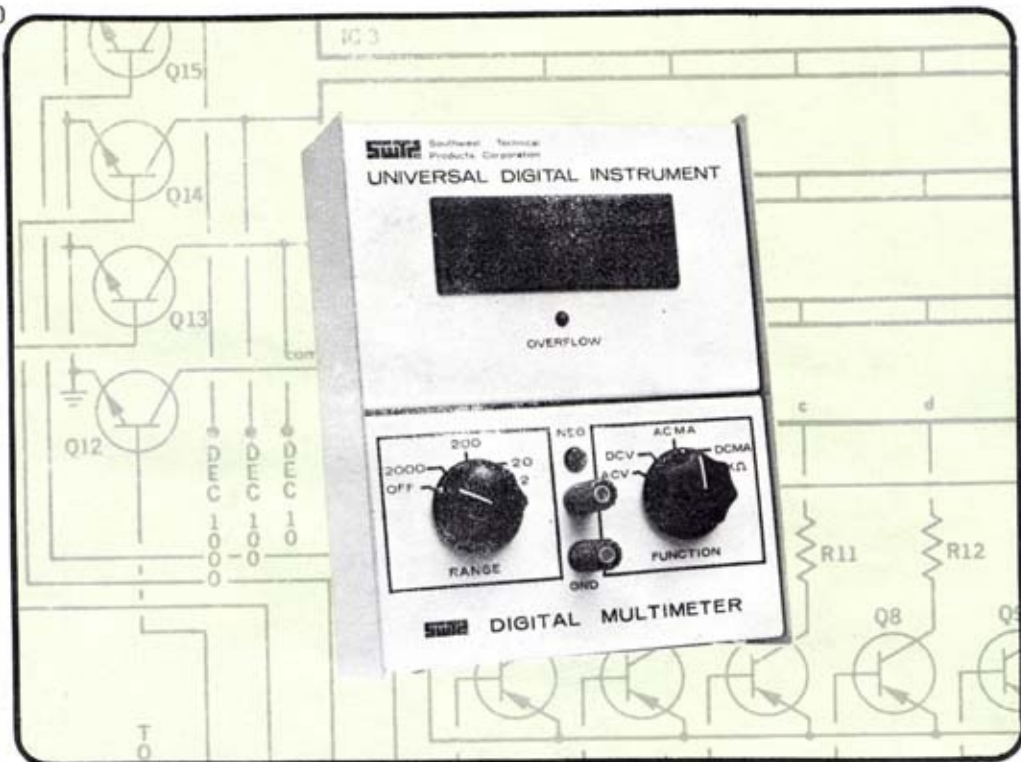

UNIVERSAL DIGITAL INSTRUMENT

- * FIRST PORTABLE DIGITAL SYSTEM
- * FOUR DIGIT READOUT
- * TIME BASE and DIVIDER
IN MAINFRAME

The first digital instrument kit to offer the convenience of portable, battery powered operation. Our new digital mainframe is without question the best possible choice for those who want a digital instrument with the most versatile possible range of applications. This system can do more and at less cost than any other digital instrument kit available. You get a full four (4) digit LED readout. Not a skimpy two digit plus overrange system

as in other low cost units. In addition to this the mainframe has its own .001% accurate crystal timebase and a programmable MOS divider circuit. This allows the mainframe to supply timing signals at almost any frequency necessary to the various plug-ins. This simplifies the circuits needed in the plug-in units considerably and makes them rather inexpensive compared to similar equipment having similar features.

The plug-in units can be changed very quickly when you want to do a different job. The instrument is housed in a rugged 6 x 7½ x 2½ steel case, which is finished with a tough epoxy enamel. With this system you will be able to make many types of measurements, with digital accuracy and at minimum cost. Photo shows the VOM-2 "Digital Multimeter" installed in the mainframe.

Universal Digital Instrument Mainframe Kit
 # UDI-1 (less any plug-in units)\$59.95 Ppd
 # UDS-1 Optional Line Power Supply
 for above.....\$11.75 Ppd



Southwest Technical Products Corporation, 219 W. Rhapsody, San Antonio, Texas

DIGITAL MULTIMETER

Measure: Volts (AC and DC), current and resistance with digital accuracy and convenience. Our digital multimeter provides you with 1% accuracy over the entire range of 2 to 2000 Volts, 2 to 2,000 Milliamps and 2,000 to 2 Meg Ohms full scale. This plug-in features an accurate, noise immune A-D conversion system that is made possible by the programmable divider in our mainframe. In addition to this you also get automatic polarity indication, and switching. No need to ever reverse the tests leads again.

VOM-2 Digital Multimeter Kit \$39.95 PPd

FREQUENCY COUNTER

Frequency counter plug-in for the Universal Digital Instrument. This plug-in allows you to measure frequency or pulse rate from 0.1 Hz to 20 MHz. with .001% accuracy (± 1 count). Sensitivity is 100 Mv. up to 2 MHz and 500 Mv maximum over 2 MHz. Input impedance is 1 Meg Ohm shunted by 20 pf. An external trigger level control is provided so that the trigger level may be set correctly on complex waveforms.

Frequency Counter Plug-in Kit—2½ lbs. # FC-3 \$24.95 PPd

TIME BASE

The time base plug-in for the Universal Digital Instrument is a good example of the simple handy plug-in units that can be offered due to our unique mainframe divider circuit. This plug-in provides a source for precision symmetrical square waves at any frequency from 1 Hz to 1 MHz. Use it for a scope calibrator, test equipment range adjustments, timing signals or any other type application that requires a stable crystal controlled frequency reference.

Time Base Plug-in Kit—2½ lbs. # TB-3 \$13.75 PPd

CAPACITY

Another very handy instrument to have around the shop. The capacity plug-in lets you measure the capacity of any capacitor from 10 pf to 10,000 mfd quickly and exactly. The circuit uses a safe low voltage for testing and a discharge system of measurement. This prevents any possible damage to low voltage capacitors and eliminates any effects that leakage might have on accuracy.

Capacity Plug-in Kit—2½ lbs. # UC-1 \$24.95 PPd

TIME PERIOD

The electronic stop watch plug-in. This handy instrument lets you time the duration of events, or the time between two events with .01% accuracy. The plug-in will time events as short as 10 microseconds, or as long as a million seconds. You can use it for high speed applications such as shutter testing on cameras, or bullet velocity, or you can use it for low speed applications such as slot car races, track and field events, etc.

Time Period Plug-in Kit—2½ lbs. # TM-3 \$14.95 PPd

Blank (unpunched) plug-in unit with connectors for your own custom plug-in designs. Painted and formed as on above units.

BP-1 \$3.95 PPd



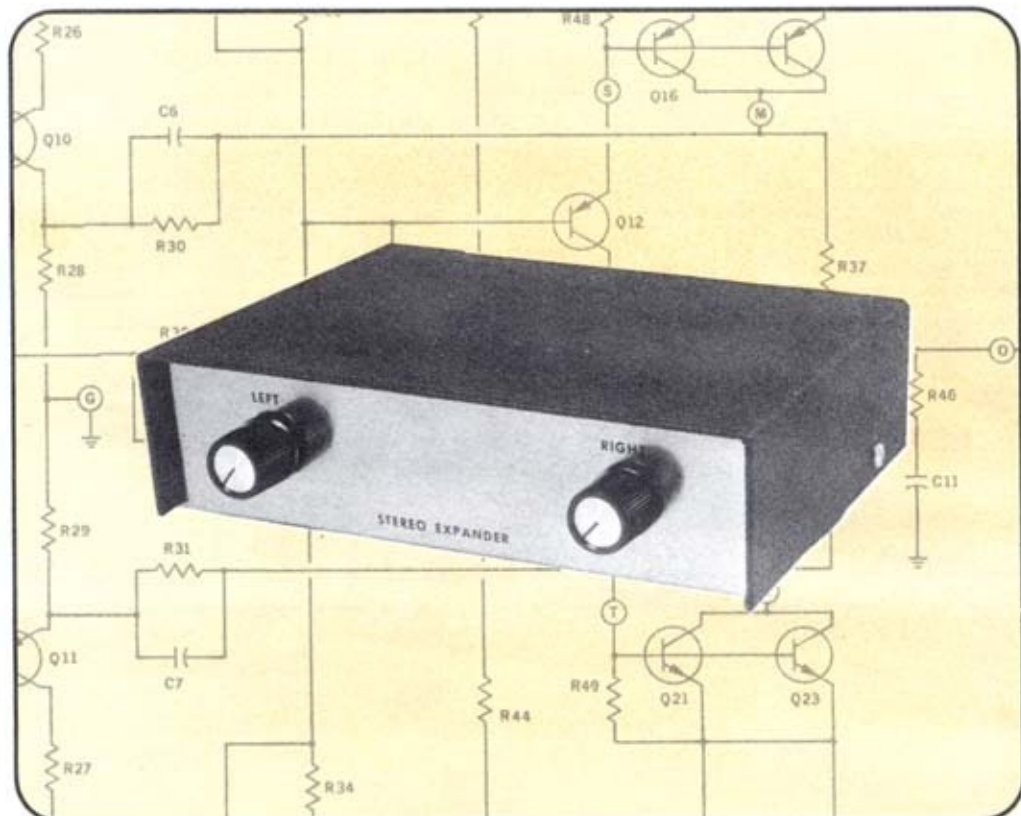

STEREO COMPRESSOR- EXPANDER

Restore the original dynamic range of the music on your records, or make your own instant background music with this versatile, high quality unit. This easy to use compressor-expander connects to the "tape monitor" jack and the "tape in" jacks on your preamp. The "Tape Monitor" button on the preamp then controls the operation of the circuit.

In the expansion mode the level at which expansion begins can be set, as can the amount of expansion. This allows you to

counteract the effects of volume compressors, etc that are commonly used to maintain a consistently high level on recordings. In many cases the improvement is dramatic.

In the compression mode, the output level is kept almost constant for up to 40 dB variation in input level. This makes it possible to convert almost any type of program into constant level background music.

SPECIFICATIONS

Adjustable for up to 20 dB of expansion, or 40 dB of compression. Less than 1% total harmonic distortion for normal input levels. Frequency response -3.0 dB at 2 Hz and 100 KHz. Hum and noise 60 dB below normal input with no expansion, 50 dB below at full expansion. Power—117 Volts AC 50-60 Hz. 7 inches wide by 2 inches high by 5½ inches deep.

Stereo Expander Kit — #EX-1
Shipping Weight 3.0 lbs. \$29.95 PPD



Southwest Technical Products Corporation, 219 W. Rhapsody, San Antonio, Texas

Dear Electronic Kit Builders,

In this edition of our catalog we are introducing our CT-1024 Terminal System. I think that we have had more letters and phone calls about this kit than anything we have ever offered. We knew that there were many uses for a low cost video display system, but we were surprised at the number of additional ones that turned up when we began talking to people about the product.

One of the reason that this kit is so widely useful is that you can buy just the pieces you need. You are not forced to buy equipment that you have no use for, because it is designed in as part of a package. Our CT-1024 features plug-in cards for additional functions, such as special cursor controls, serial interface, parallel interface and screen read. Even the power supply is a separate item, just in case you already have suitable supply voltages available. This way you don't find yourself spending hundreds of extra dollars for features that are not useful to you.

You will note that all of our power amplifiers now have power output specified in the FTC approved manner. I do not agree that this bureaucratically composed passage conveys power output information in a way that is less confusing than specifications that we and other component manufacturers had previously used. It actually limits the amount of information that we can supply you unless we endlessly repeat the prescribed piece of gibberish that the FTC has proclaimed to be the acceptable way. Once more consumers are going to receive less information than before due to governmental messing into areas that really did not have a problem to begin with.

Daniel Meyer



TWO UNIQUE COLOR ORGANS

PSYCHEDELIA III

"CLASSICAL" FILTER SYSTEM
4 - 800 WATT CHANNELS
WORKS WITH ANY SOUND SYSTEM

The best of it's type. Psychedelia I is the only color organ available using a ramp triggering system. This unique system pioneered by SwTPC, produces a light output that is closely proportional to the sound level in each channel. There are no circuits that produce a lag in light response, other than the lamps in the display itself. Lamp power is changed at a 60 per second rate.

The four channels are generated by op-amp driving active filters. These filters have 12 dB per octave slopes to minimize crosstalk and bleed through from one channel to another. The input is transformer isolated and may be connected to any speaker terminals with safety. Due to the sensitivity of this circuit only a fraction of a Watt is needed to drive the system and as a result the connection cannot possibly affect your sound system in any way.

Psychedelia I corrects automatically for variations in sound level. A compressor circuit with 40 dB range allows you to operate your system at any level from 5 Milliwatts to 50 Watts without readjusting the color organ controls. This completely eliminates the need to reset sensitivity every time you change the volume.

QX III - Four Channel Kit - 4 lbs.....\$44.95 PPd
QX III A - Assembled Kit - 4 lbs.....\$60.00 PPd

SPECIFICATIONS

Dimensions (circuit board w/parts)8 $\frac{1}{2}$ "x5 $\frac{1}{2}$ "x2 $\frac{1}{2}$ "
Input Impedance: stereo..... 100 Ohms
 monaural..... 50 Ohms
Bands:Low..... approximately 60 Hz - 240 Hz
 Med. Low 240 Hz - 960 Hz
 Med. High 960 Hz - 3840 Hz
 High 3840 Hz - 15,360 Hz
Power Handling capability ... 800 watts of 117 Volt
 lamps per channel
Circuitry Power Requirements, 117 Volts 100 Watts

PSYCHEDELIA II

NEW DIGITAL SYSTEMS
4 - 800 WATT CHANNELS
WORKS WITH ANY SOUND SYSTEM

A new approach to color organ circuits. Psychedelia II uses a sampling system and digital counting techniques to separate the sound input into four channels. The sample rate is adjustable from 5 to 50 times a second to produce the amount of display activity you want. The display action that results from this system is considerably different from the more common filter type color organ. First of all there is only one color lamp on at any time. However persistence of vision will produce the illusion of all lamps being on under some conditions of input signal. Due to the sampling process used, the display is more active as it switches rapidly from one color to another. This also tends to make the display seem more random. The display will not follow music in quite as obvious a fashion as a filter color organ. Since it will not sync with the music in the same way twice the display will be different even if the same selection is played again.

The input is transformer isolated and may be connected safely to any systems speaker terminals. The sensitivity is great enough to prevent loading of the amplifier and you will not effect the sound system in any way by using this color organ.

QX-II Four Channel Kit - 4 lbs.....\$44.95 PPd
QXA-II Assembled Kit - 4 lbs.....\$60.00 PPd

SPECIFICATIONS

Dimensions (circuit board w/parts)8 $\frac{1}{2}$ "x5 $\frac{1}{2}$ "x2 $\frac{1}{2}$ "
Input Impedance: stereo..... 100 Ohms
 monaural..... 50 Ohms
Bands:Low..... approximately 60 Hz - 240 Hz
 Med. Low 240 Hz - 960 Hz
 Med. High 960 Hz - 3840 Hz
 High 3840 Hz - 15,360 Hz
Power Handling capability ... 800 watts of 117 Volt
 lamps per channel
Circuitry Power Requirements, 117 Volts 100 Watts

