

NEW LOOK — NEW STORIES — NEW DEPARTMENTS

Popular Electronics

FIFTY CENTS / OCTOBER 1970

Indestructible 125-Watt Power Amp

Graphic Stereo Tone Control

EDISON—INVENTOR
OF WIRELESS!

REFORMING YOUR
ELECTROLYTICS

VHF-UHF GRID-DIP
OSCILLATOR

MEASURING RESISTANCE
BELOW 1.0 OHM

PHOTO ENLARGER
LIGHTMETER

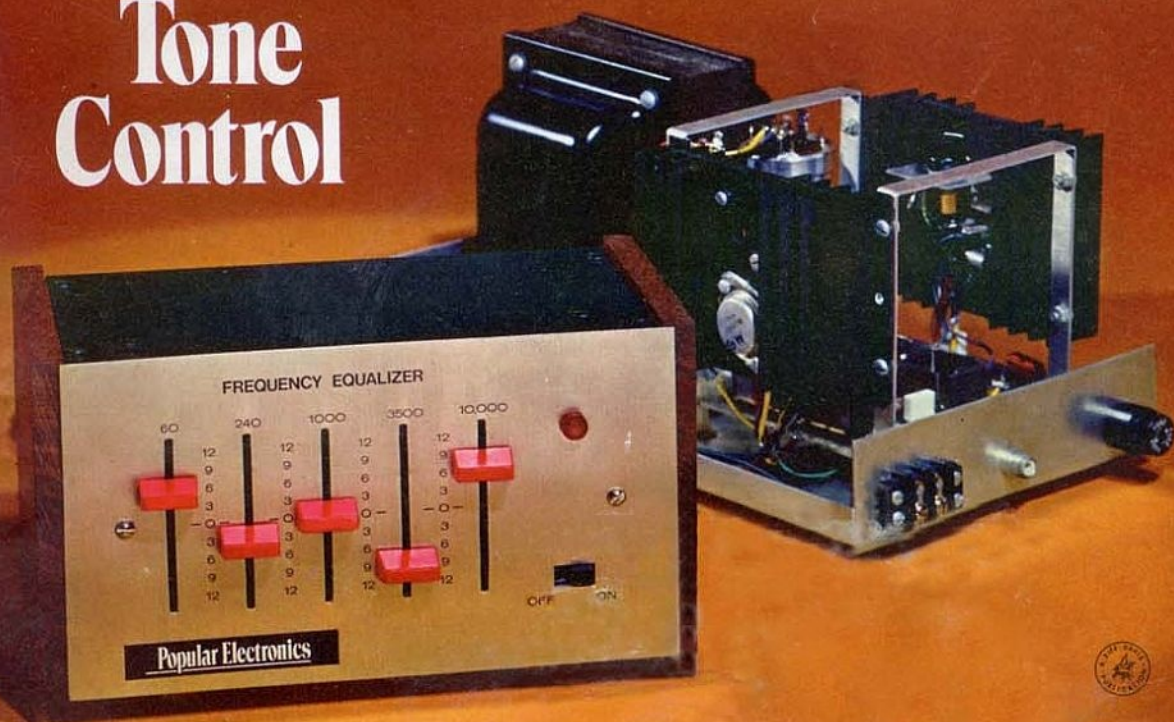

BY DAN MEYER



Assembling a

UNIVERSAL TIGER

A UBIQUITOUS, 125-WATT-
PER-CHANNEL DESIGN

This power amplifier design is the culmination of various "Tiger" amplifier projects developed by the same author. It is virtually indestructible and our exhaustive tests reveal that no combination of input-output mismatching and short circuits can cause amplifier failure. The performance specifications equal or better numerous commercial quality hi-fi power amplifiers.

NO HI-FI power amplifier can be all things to all men, but the "Universal Tiger" comes closer to the ideal than you might think. Consider the following: The output power of the Universal Tiger can be set to any level between 10 and 120 watts rms/channel by connecting to the amplifier circuit an appropriate power supply (12-40 volts dc). Over the audio spectrum, distortion is never more than 0.5% and it can be reduced to less than 0.05% at the user's option. The bandwidth between the 3-dB down points is 1-100,000 Hz!

And that's not all. No external load, short circuit, or input condition can cause amplifier failure. The most that will happen is a blown fuse. Thermal stability is so good that the output transistors operate with a heat sink temperature of 100° C (the boiling point of water) with no tendency to self-destruct. Nor is there any danger of speaker damage due to a starting transient since there are no large capacitors in the circuit that must charge up before normal operation can begin. When the Universal Tiger is turned on a small click is heard in the speaker system, then instant sound.

Construction. The driver and voltage amplifier stages of the Universal Tiger are assembled on a printed circuit board, the actual size etching guide and component placement diagram for which are shown in Fig. 2. The circuit board is designed to match the space requirements of the "Super Tiger" (see "Tigers That Roar," POPULAR ELECTRONICS, July 1969) so that builders of the earlier project can easily update it.

The chassis and power supply for the Super Tiger can also be used with the Universal Tiger if no more than 80 watts mono or 60 watts/channel stereo output is desired. If you want a lower output power, one of the

low-voltage transformers listed in the sidebar should be used. And with a 4-ohm load and a heavy-duty power supply (see Fig. 3) for each channel, a 125 watts rms/channel stereo system can be built.

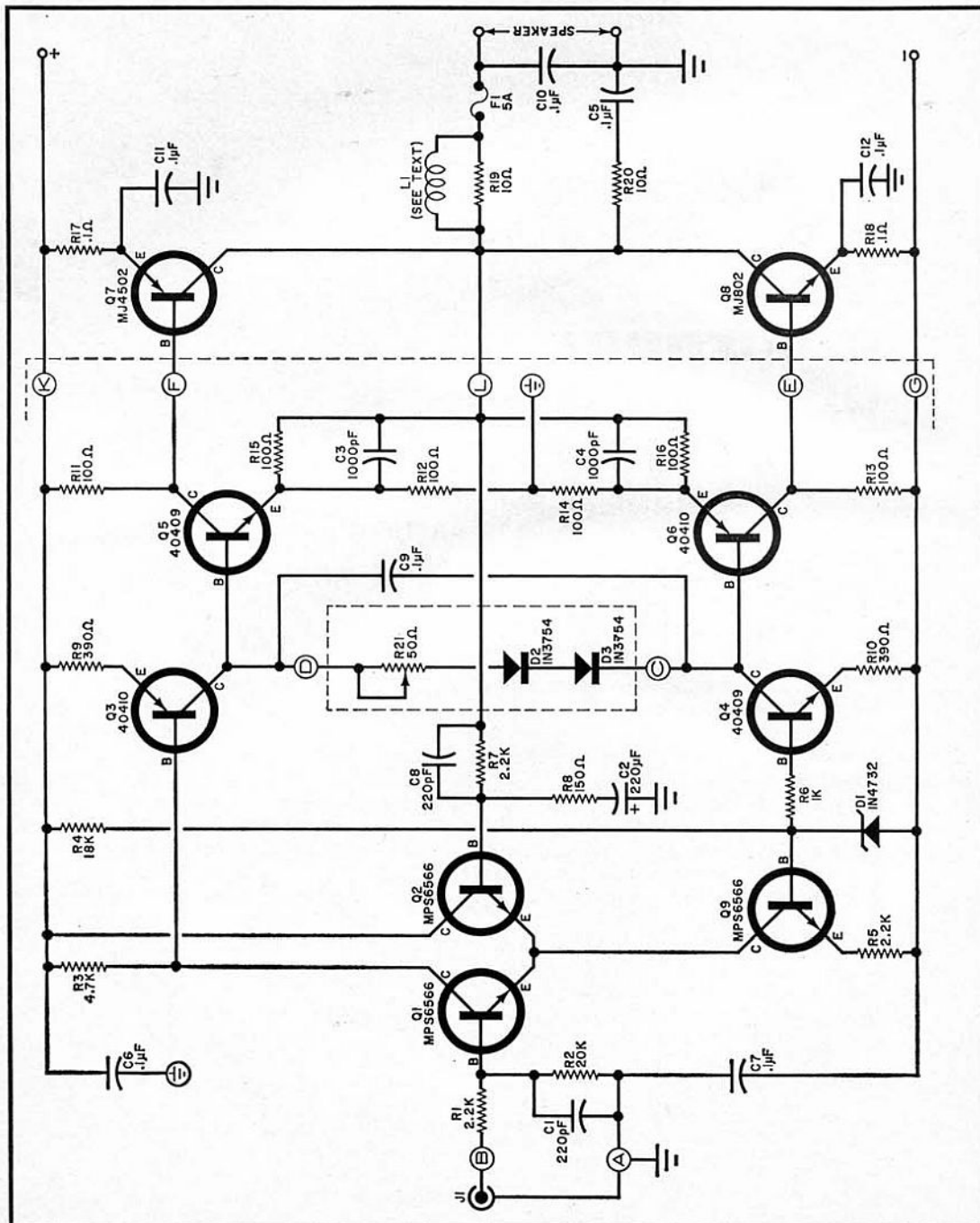

The power supply circuit is simple and straightforward. However, depending on the amount of power you want from your amplifier, you will have to select the proper secondary voltage-current rating for transformer

PARTS LIST AMPLIFIER

- C1,C8—220-pF capacitor
C2—220- μ F, 6.3-volt electrolytic capacitor
C3,C4—1000-pF capacitor
C5-C7,C9—0.1- μ F capacitor
C10-C12—0.1- μ F disc capacitor
D1—4.7-volt zener diode (1N4732 or HEP602)
D2,D3—1N3754 or HEP 156 silicon diode
F1—5 ampere standard—NOT slow-blow—fuse
J1—Phono Jack
Q1,Q2,Q9—MPS-6566 transistor
Q3,Q6—Transistor (RCA 40410)
Q4,Q5—Transistor (RCA 40409)
Q7—Transistor (Motorola MJ4502)
Q8—Transistor (Motorola MJ802)
R1,R5,R7—2200-ohm, 1/2-watt
R2—20,000-ohm, 1/2-watt
R3—4700-ohm, 1/2-watt
R4—18,000-ohm, 1-watt
R6—1000-ohm, 1/2-watt
R8—150-ohm, 1/2-watt
R9,R10—390-ohm, 1/2-watt
R11,R16—100-ohm, 1/2-watt
R17,R18—0.1-ohm, 5-watt
R19,R20—10-ohm, 1-watt
R21—50-ohm potentiometer

All resistors
10% tolerance

Misc.—Steel chassis (6" x 11"); Wakefield Semiconductor No. NC403C or Thermalloy Co. No. 6403B heat sinks (2); two-lug ungrounded terminal block; four-lug terminal strip; 22-18-gauge aluminum stock for U and L brackets; #18 or larger stranded hookup wire; fuse holder; #6 and #4 machine hardware; diode clamps (2); solder lugs (2); three-lug terminal strips (2); transistor mounting hardware; solder; etc.

Note—The following items are available from Southwest Technical Products Corp., 219 West Rhapsody, San Antonio, TX 78216: circuit board (No. 175B) for \$2.75; complete amplifier as listed, but excluding chassis (No. 175C) for \$30 plus shipping and insurance on 3 lb; complete stereo version with punched chassis and power supply (No. 2S-175) for \$80 plus shipping and insurance on 17 lb; complete single-channel version with punched chassis and power supply (No. S-175) for \$60 plus shipping and insurance on 14 lb.

Fig. 1. Circuit of power amplifier is simple and foolproof in design. Note absence of "weak link" large-value capacitors. Two such amplifier circuits are required for stereo system.

T1 and the current rating of fuse F1 from the table in the sidebar.

The power supply mounts directly on the steel chassis that accommodates the amplifier circuits. Point-to-point wiring is used throughout, but be extremely careful during wiring to make sure diode and capacitor polarities are correct.

Since the physical layout of the Super Tiger was presented previously, this article will focus on the construction of only the 125-watt mono version with power supply.

Unless you purchase the steel chassis with the complete kit from the source listed in the Amplifier Parts List, you will have to machine your own, using the photos given in this article to guide you.

After mounting and soldering into place the components on the circuit board, solder 8" lengths of #18 or larger stranded hookup wire at hole locations C and D from the foil side of the board and at locations G, GND, E, L, F, and K from the component side. Twist together 2 1/2" lengths of black and white wires. Solder the black wire to A and the white wire to B on the component side. Then mount the circuit board in its proper location on the chassis.

At the opposite end of the chassis, anchor the power transformer with #8 hardware and the filter capacitors with #6 hardware. Fasten the power supply primary fuse holder and line cord with strain relief in their appropriate holes on the rear apron of the chassis. Then bolt down the secondary fuse block and the terminal strips associated with

TECHNICAL SPECIFICATIONS

Output power: Up to 80 watts/channel with 8-ohm load; to 120 watts/channel with 4-ohm load

Distortion: Less than 0.5% from 20 to 20,000 Hz standard; less than 0.05% from 20 to 20,000 Hz with optional low distortion adjustment

Frequency response: 3 dB down at approximately 1 and 100,000 Hz

Hum and noise: Better than 80 dB below 1 watt rms output

Damping factor: Better than 100 with 8-ohm load

Sensitivity: 1.5 volts rms input for full output

Stability: Completely stable with any source impedance; can be used with any load impedance as low as 3 ohms or capacitive loads to 1 μ F.

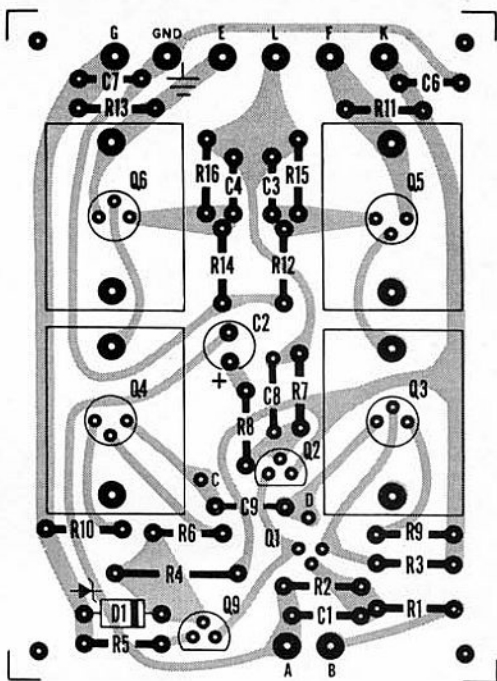
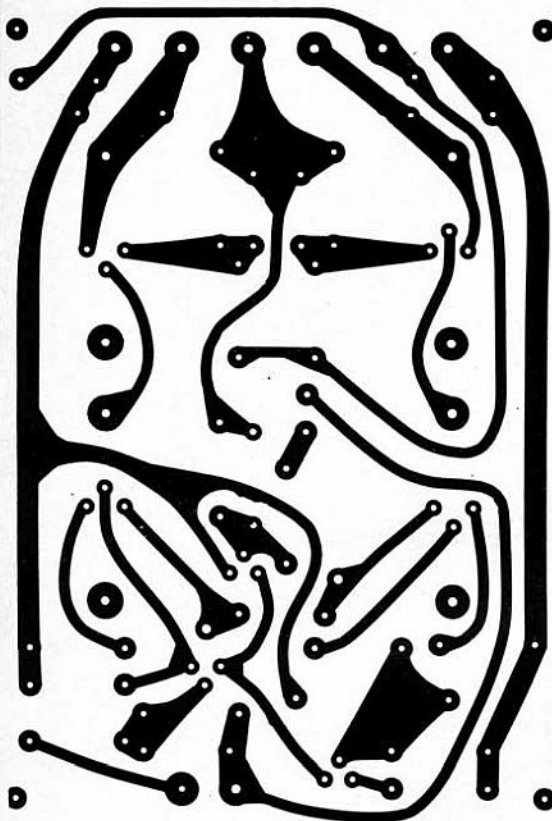

Fig. 2. Actual size etching guide is shown at left. In component layout and orientation diagram (above), boxes around Q3-Q6 represent outlines of heat sinks on these transistors.

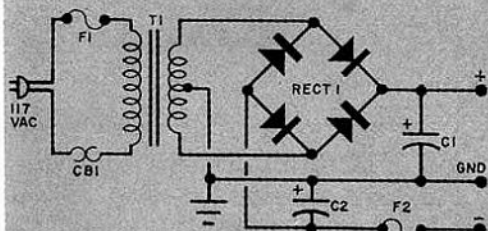

Fig. 3. Negative dc supply voltage is taken from right side of F2. Table lists ratings of F1 and T1 for desired amplifier output.

POWER SUPPLY PARTS LIST

- C1, C2—4000- μ F, 50-volt electrolytic capacitor
 CB1—200° thermostat (No. L200 88-4, available for \$5 from Elmwood Sensors, Inc., 1655 Elmwood Ave., Cranston, RI 02907)
 F1—Slow-blow fuse (see table for rating)
 F2—5-ampere standard—NOT slow-blow—fuse
 RECT1—Full-wave bridge rectifier assembly (Motorola MDA962-3), or substitute four 3-ampere, 200 PIV silicon diodes

POWER SUPPLY COMPONENTS

Output Power	F1 Current	T1 Secondary Voltage & Current	DC Output
125 W*	2.6 A	62 V ct, 3 A	± 40 V
80 W	2.6 A	62 V ct, 3 A	± 40 V
40 W	1.5 A	45 V ct, 2 A	± 28 V
20 W	1.0 A	34 V ct, 1.5 A	± 20 V
10 W	1.0 A	24 V ct, 1 A	± 15 V

*At 4-ohm load; all other power ratings referenced to 8-ohm load impedance.

T1—117-volt primary (see table for secondary voltage and current ratings) power transformer

Misc.—Fuse holder; fuse block; ac line cord with plug; line cord strain relief; #18 or larger stranded hookup wire; #6 and #8 machine hardware; two-lug—neither grounded—terminal strips (2); five lug—center lug grounded—terminal strip; solder; etc.

Note—All above items available from Southwest Technical Products Co. as part of kits S-175 and 2S-175 (see Amplifier Parts List).

Fig. 4. Power supply secondary fuse and bridge rectifier assembly diodes mount on fuse block and terminal strip. Resistors R17 and R18 connect output of power supply to Q7 and Q8 in amplifier circuit.

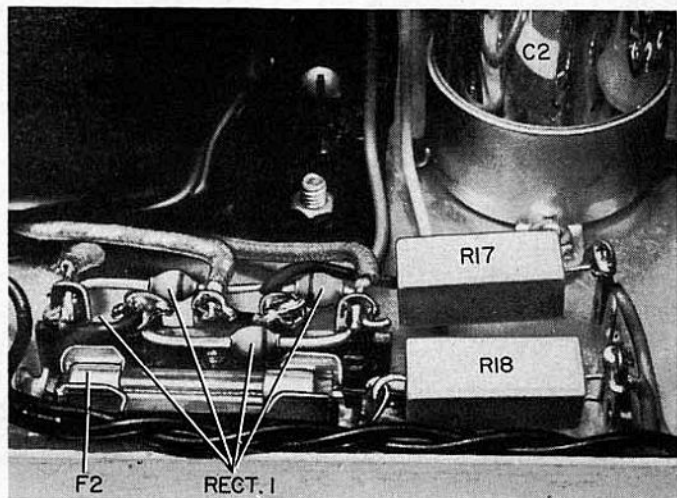

the power supply (see Fig. 4). Now, referring to Fig. 3, wire together the power supply circuit, using #18 or larger stranded hookup wire. (Note: Where #18 or larger wire is specified, do not substitute a smaller size wire. The circuits to which these wires connect carry as much as 10 amperes when the amplifier is driven to full power. If too small a wire size is used, power will be sacrificed and damping will suffer.)

Returning to the amplifier end of the chassis, mount input jack *J1*, the speaker fuse holder, and the output terminal block on the front apron. Solder the white wire from hole B on the circuit board to the center contact of *J1* and the black wire from hole A to the

other lug on *J1*. Bolt a four-lug terminal strip (one lug grounded) to the chassis at the right of the circuit board and in line with the speaker fuse holder.

Close-wind one layer of #26 enameled wire along the entire length of the body of *R19* (10-ohm, 1-watt resistor). Scrape the ends of the wire and solder them to the leads of the resistor. Then solder one lead of this *L1/R19* assembly to the center lug on the output fuse holder and connect the other lead to the lug nearest the fuse holder on the last terminal strip mounted.

As shown in Fig. 5, connect *C5* and *R20* to the terminal strip near *R19/L1*. Solder only the ground lug that serves as the tie

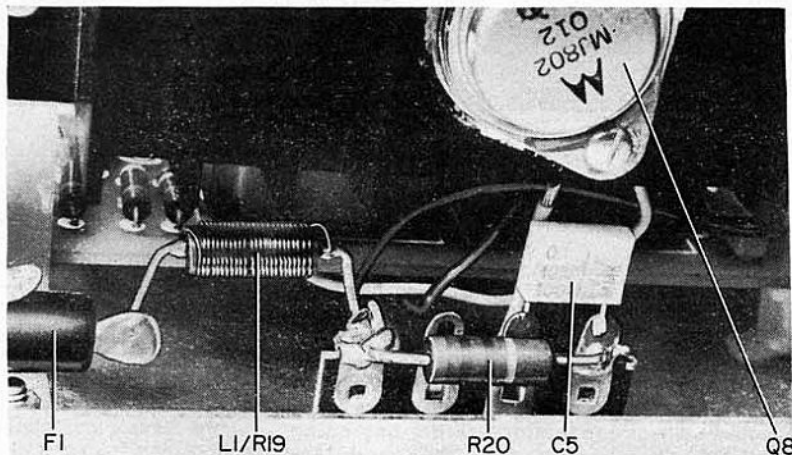
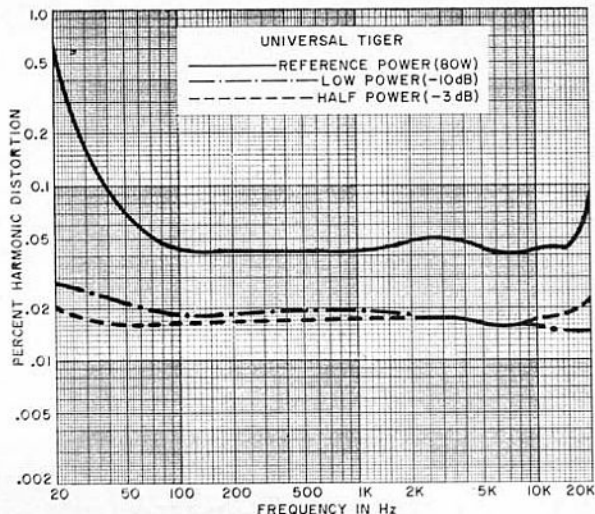

Fig. 5. Close-wind a single layer of #22 enameled wire along the entire length of *R19* and solder the wire ends to the resistor leads to make the *L1/R19* assembly.



HIRSCH-HOUCK LABORATORIES Project Evaluation

This is a very impressive basic amplifier for a home-brew project. The schematic diagram of the "Universal Tiger" is reminiscent of the new Harman-Kardon "Citation 12," with an operational amplifier input configuration and overall direct-coupled feedback to maintain the speaker at dc ground. However, unlike the Citation 12, the Tiger uses complementary symmetry output transistors, and opposite polarities on the other transistors.

In general, we confirmed Mr. Meyer's specifications figures. Where he claims a 0.01% or less distortion under most op-

erating conditions, we feel that he is a trifle optimistic, but he certainly comes close. At 80 watts, the distortion is typically less than 0.05% from 70 to 17,000 Hz, rising to slightly in excess of 0.5% at 20 Hz. At half power or less, the distortion is typically less than 0.02% from 20 to 20,000 Hz.

At 1000 Hz, distortion falls from 0.15% at 0.1 watt to a minimum of 0.009% at 20 watts and rises to 0.1% at 85 watts, which is just below clipping level. These powers were measured with an 8-ohm load and a 117-volt line.

Intermodulation distortion was slightly higher. But at most power levels greater than one watt, it was less than 0.1%. We did not have enough voltage from our IM analyzer to drive the amplifier to more

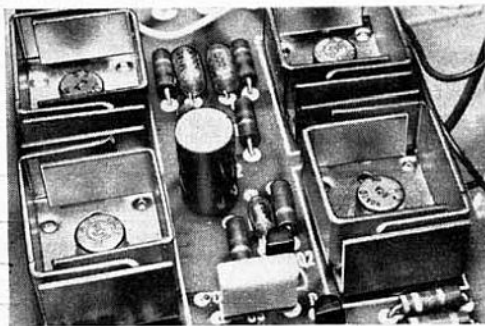

When mounting Q3-Q6 on printed circuit board, make certain that triangular lead configurations and heat sink tabs line up with holes in circuit board.

point for both *C5* and *R20*. Temporarily set aside the chassis assembly.

Spread a film of silicone paste on the bottom of the case of *Q7* (MJ4502) and slip onto the pasted side a mica insulator. Spread another film of the paste on one of the heat sinks in the area over which *Q7* is to be mounted. Then seat *Q7* on the heat sink. Push a #4 machine screw through the mounting hole tabs in the case of the transistor, turn over the assembly, and slide onto each screw a shoulder fiber washer. Make sure that the shoulders engage the oversize holes in the heat sink. Then place a solder lug over the screw nearest the edge of the heat sink and a three-lug terminal strip and a diode case

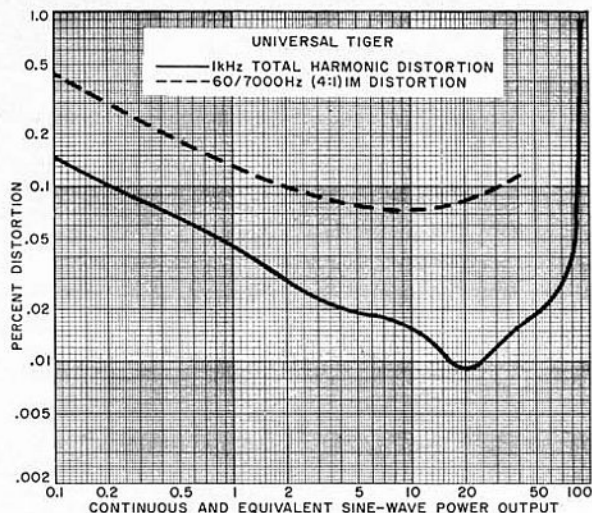

than 40 watts. These figures were measured with the bias adjust control set as received with best thermal stability. The low-level distortion could be reduced substantially with this control set at its opposite limit, where the measured reduction was from 0.045% to 0.023% at one watt and from 0.15% to 0.047% at 0.1 watt. However, it is hardly worth the bother to play with the bias adjust control, since we doubt that many people have the test equipment needed to make the adjustment.

Into 4 ohms, the maximum power at the clipping point was 97 watts; into 8 ohms, it was 92 watts; and into 16 ohms, it was 53 watts. An input of 0.9 volt was needed for a 10-watt output (our standard reference level) and hum and noise were

86 dB below 10 watts—a very low figure.

The frequency response of the Universal Tiger was ± 0.2 dB from less than 10 Hz to beyond 20,000 Hz. It was down 0.3 dB at 5 Hz and 50,000 Hz, and the higher end was slightly better than claimed, being down 1.1 dB at 100,000 Hz and 3.9 dB at 200,000 Hz. Square wave tests showed a rise time of about 2.5 microseconds.

In all, the Universal Tiger is one of the best power amplifiers we have had the pleasure of testing. Short-circuiting the output at full power blew only the speaker fuse, while full power square-wave drive at 100,000 Hz blew only the power supply fuse after a few moments. But nothing seemed to damage the amplifier circuit itself.

clamp over the other screw. Fasten the screws with appropriate nuts. Use #4 hardware to bolt CB1 in place.

Repeat the above procedure for the second heat sink and Q8 with the following changes. Anchor only the diode clamp and solder lug to the hold-down screws for Q8. Mount R21 on an L bracket and fasten the bracket and a three-lug terminal strip to the heat sink with #4 hardware and shoulder fiber washers.

Slide D2 and D3 into the diode clamps and push onto the diode leads 1" lengths of plastic tubing. Connect the leads to the ungrounded lugs of the terminal strips. Solder a 10"-long wire to the lug to which the anode lead of D3 is connected and a 1" wire from lug 3

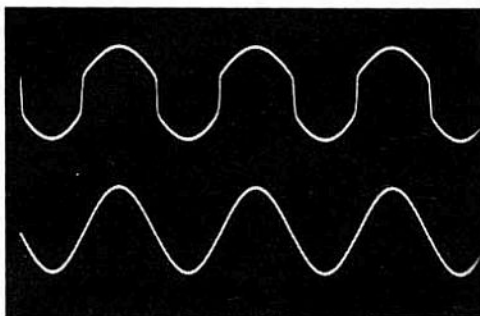

In upper waveform, crossover distortion at base of Q4 can be seen; lower trace shows undistorted waveform (F=1000 Hz at 0.25 watts into 8-ohm load).

THEORY OF CIRCUIT DESIGN

The circuit of the Universal Tiger is a combination of operational amplifier and complementary output techniques. As shown in Fig. 1, transistors $Q1$ and $Q2$ form a differential amplifier. The input signal is applied to the base of $Q1$, with negative feedback on the base of $Q2$.

Zener diode $D1$ maintains a constant bias voltage on $Q9$ so that the current is constant through the base-emitter circuit of the transistor for any supply potential exceeding 4.7 volts. Hence, the $Q9$ circuit functions as a constant-current source for $Q1$ and $Q2$. Since $C2$ provides for 100 percent negative feedback in the circuit, the output voltage offset is on the order of a few millivolts; any unbalance is immediately corrected by the $Q1/Q2$ differential stage. And the ratio of $R7$ to $R8$ determines the amount of overall ac negative feedback. (Note that $C2$ is the only element in the circuit that prevents the amplifier from responding down to dc.)

From the collector of $Q1$, the amplified signal goes to the base of $Q3$. Normally, $Q3$ would be the voltage amplifier that supplies the large voltage swing needed to drive the impedance-matching driver/output circuit. Here, however, it is limited in voltage gain and, working with $Q4$, it provides some unique characteristics.

In most of the common amplifier circuits, the voltage amplifier load resistor is split (as in Fig. A), and a "bootstrap" capacitor is connected to the output. This causes the voltage across collector load resistor R_L to remain at a constant value so that collector current is constant. If a constant-current circuit were not used, the amount of current available to drive the output circuit would drop to zero as the positive peaks of the waveform approach the peak positive potential of the power supply. This would result in a considerable amount of distortion on positive peaks that would be difficult or impossible to correct no matter how much degenerative feedback was used.

In the circuit of the Universal Tiger, an active current source is used instead of the more common bootstrap system. The results are the same with one important exception. The driver is not affected by supply voltage variations, due to the use of a constant load resistance, and a solution is provided for the crossover distortion problem because the active current source supplies a constant current to $Q3$ at all times. The bootstrap circuit, obviously, does not.

Consider what happens if a portion of the output waveform is flat, as from A to B in Fig. B, due to an underbiased condition in the output stage. During this portion of the cycle, there is no increase in output voltage, and, as a

result, no bootstrap action by the capacitor. And during this time the circuit does not provide the driver transistor with a constant current. With the active current source, this does not occur.

The active current source actually eliminates most of the crossover distortion that can occur due to an underbiased condition in the output circuit. We can see why if we consider what a constant current source does. It adjusts the voltage to keep the current through the circuit constant. But what happens if an underbiased condition exists in which $Q5$ and $Q6$ are both cut off?

As the driving voltage approaches zero, the active driver begins to turn off, but the voltage is not yet sufficient to cause the other driver to conduct. The loading on the current source becomes far less during this period since no current can be supplied to either driver while both are cut off. Hence, the current source increases the voltage in an attempt to maintain a constant current through the amplifier circuit. And the driving voltage jumps very quickly from the cutoff point of one driver to the conduction point of the other driver, resulting in the minimum of effect on the output waveform during the crossover period.

In a case like this, the bias on the output stage would normally be adjusted so that both output transistors are conducting at a low level to avoid crossover distortion. However, if it is possible to avoid having to make a critical bias adjustment, so much the better. Without making this adjustment, a considerable problem in thermal stability will result. As the transistor's temperature increases, the same bias voltage will cause a considerable increase in collector current, opening the way to possible thermal runaway. The use of diodes $D2$ and $D3$ in the Universal Tiger provides automatic adjustment which helps to eliminate the thermal problem.

The diodes are actually mounted on the heat sinks used for $Q7$ and $Q8$. Now, any temperature changes in the output transistors are detected by the diodes, whose resistances vary with temperature. As the diode resistances change, so do the bias voltages to driver transistors $Q5$ and $Q6$. Hence, if $Q7$ and $Q8$ begin to operate abnormally hot, the diodes increase the bias voltage to $Q5$ and $Q6$ and indirectly lower the operating temperature of $Q7$ and $Q8$.

There are two types of compound connections commonly employed in the output stages of transistor power amplifiers. These are shown in Fig. C. The quasicomplementary circuits which use only one polarity of power transistors have one of each type in their output stage. The double emitter follower compound system requires two diode drops to bias it on, while the double common emitter compound requires only one diode. This is a slight ad-

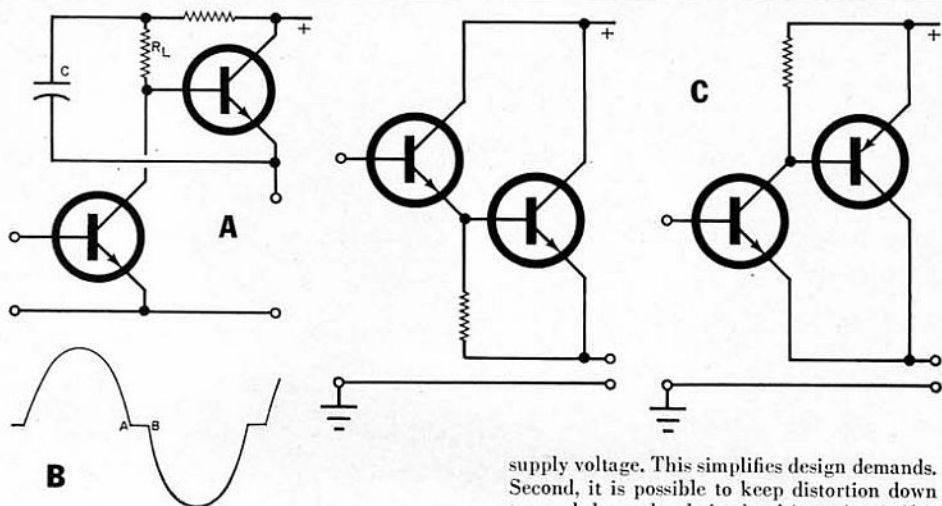

vantage since one less diode must be included in the temperature-compensated bias network.

Neither compound has any voltage gain; both require a driving signal voltage swing equal to the needed output. Since the common emitter driver compound at the right in Fig. C has 100 percent degenerative feedback, gain matching is not required in the output transistors, just as in the double emitter compound also shown.

Comparison of the two circuits as a power output stage gives the circuit at the right a slight advantage in lowest distortion and other areas if the circuit has overall negative feedback.

While testing a full complementary circuit using the common emitter compound, it appeared that there was really no reason why 100 percent degenerative feedback should be necessary or even desirable in the driver transistor. With a complementary circuit it is not necessary to rely on a double emitter follower for half of the output—which requires a second half with matching drive voltage requirements. A complementary circuit allows the use of any amount of degenerative feedback from zero to 100 percent in the driver portion of the circuit. A circuit with no degeneration can provide the maximum amount of voltage gain from two transistors, but it requires matched gains in the output transistors.

Since there is plenty of gain available elsewhere in the circuit of the Universal Tiger, a 50 percent feedback arrangement was selected for the driver stage. This gives a gain of two in the output stage and enough feedback to make transistor matching unnecessary.

The gain of only two might appear to be too small, but it does provide several substantial benefits. First, the peak-to-peak drive voltage excursion need be only half that of the peak

supply voltage. This simplifies design demands. Second, it is possible to keep distortion down to much lower levels in the driver circuit if it does not have to develop full supply positive and negative excursions. Additional temperature stability, by using 50 percent feedback in the output stage, is yet another advantage.

Even without the current drive system, the circuit of the Universal Tiger would have been many times more stable than circuits employing 100 percent degeneration in the driver. Another bonus is that the output stage is virtually failure proof.

If the output of the circuit in Fig C is short circuited, or too low an impedance load is connected to it, the driver transistor would attempt to put enough current through the base-emitter junction of the output stage to bring the voltage up (due to overall feedback effects). This can cause the collector current rating of the driver transistor or the base-emitter rating of the power transistor, or both, to be exceeded. The same thing can also happen in the second circuit, but in a slightly different manner; therefore elaborate protection circuits must be designed to prevent this.

This situation cannot occur with a 50 percent feedback arrangement. The driver's emitter resistor limits the amount of current that can pass through the emitter-collector circuit and into the base of the output transistor. The base current is limited to a value that does not allow collector current in the output transistor to exceed its rating. Hence, short-proof protection is built in and works automatically.

Since the output transistors specified in Fig. 1 have a 30-ampere rating, a fuse in the output line and another in the primary circuit of the power supply transformer will circumvent any possible damage that might otherwise result from overloading. Also, to provide the maximum amount of protection against damage CBI in Fig. 3 is used on one of the output transistor heat sinks.

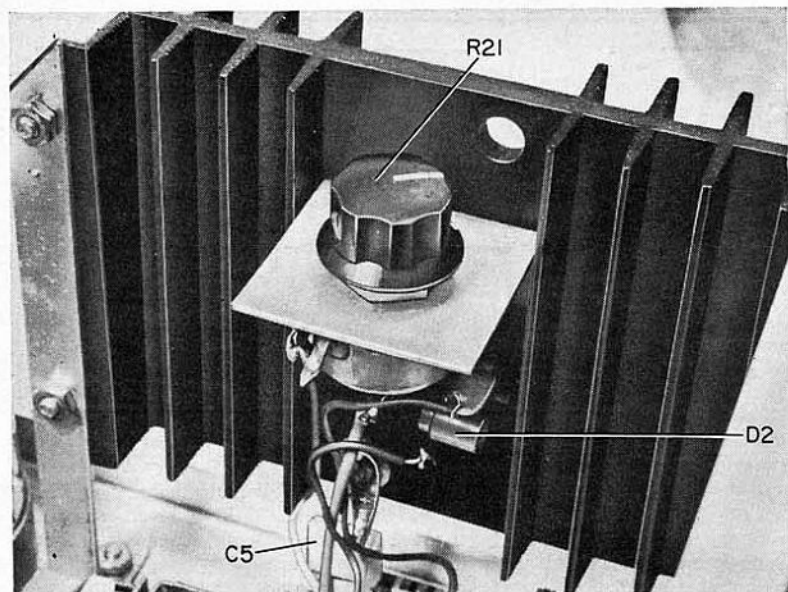

Distortion control R21 fastens to heat sink on which Q8 is mounted with small L bracket and machine hardware. Terminal strip for D2 mounts directly below R21.

of R21 to the *anode* lug of D2. Then solder an 8"-long, #18 or larger wire to the solder lug on Q7 and a 3"-long wire to the solder lug on Q8.

Use #6 hardware to bolt the U brackets to the chassis. Mount the heat sink assembly on which Q7 is mounted to the left sides of the brackets. Solder the wire from hole C on the circuit board to the *cathode* lug of D3 on the terminal strip. Connect and solder a 6"-long, #18 or larger wire between R17 and the emitter lead of Q7. Then solder the lead from hole F on the circuit board to the base lead of Q7. Route the lead connected to the solder lug on Q7 under the board, and connect it to the lug at the junction of L1/R19 and R20.

Now, mount the other heat sink assembly in place. Connect and solder the lead from the solder lug on Q8 to the L1/R19 and R20 junction lug. (There should now be five wires connected to this lug.) Locate the lead from hole D on the circuit board and remove $\frac{3}{4}$ " of insulation from the free end. Connect and solder this wire to lugs 1 and 2 of R21. Route an 8"-long, #18 wire from the emitter of Q8, under the board, and to R18. Solder both connections. Then route the 10" wire from the *anode* connection lug of D3 under the board and connect the free end to the

cathode connection lug for D2. Solder the wire from hole E on the board to the base lead of Q8.

Finish the wiring as follows. Solder a 6" wire between the side lug on the speaker fuse holder and the lug nearest the fuse holder on the output terminal block, and an 8" wire from the ground lug on the rectifier bridge terminal strip to the other lug on the terminal block. Cut two wires to 12" lengths, strip the ends, twist them together, and connect one end of the pair to the lugs on CB1 and the other end to the lugs on the terminal strip located between the two fuse holders in the power supply. Finally, solder the free ends of the wires on the circuit board to the appropriate points in the power supply filter section.

Insert a 5-ampere *standard* fuse in both the speaker fuse holder and the power supply secondary fuse block. For the rating of the primary fuse, refer to the table in the power supply sidebar for the particular output power selected.

Adjustment and Use. If the Universal Tiger is to be used with any but the very best speaker system, the circuit can be assembled without distortion control R21. (In this event, simply connect the wire from hole D on the

circuit board directly to the lug to which the anode of *D2* is connected.) However, with a first-rate speaker system where there is a possibility of noticing the difference between 0.1% and 0.01% distortion, *R21* should be added as shown.

Control *R21* allows adjustment of the bias to eliminate crossover distortion completely. Thermal stability will not be quite as good, but with a sound system there is little danger of overheating since few people would operate the amplifier continuously at its full rated power.

To set *R21*, adjust the potentiometer for minimum resistance and the amplifier for approximately a 1-watt output into a load. Observe the waveform at the base of *Q5* on an oscilloscope. Increase the resistance of *R21* until the waveform is distortion free. Check the idle current of the amplifier; it should be approximately 50 mA. Then seal the adjustment.

The Universal Tiger should give years of trouble-free operation if it is properly assembled. It is doubtful that any improvements in amplifier design during the next few

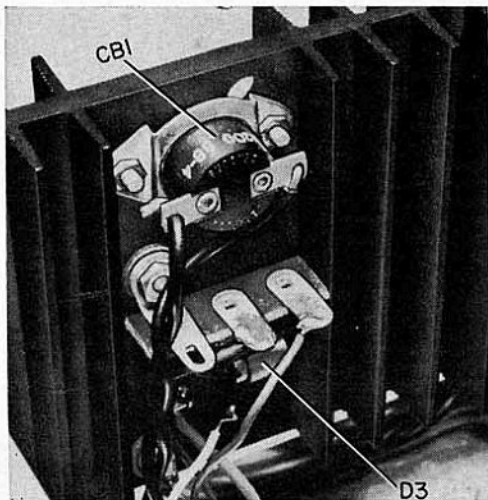

For proper operation, sensing element of thermal circuit breaker CB1 must contact Q7's heat sink.

years will produce an improvement in sound quality when compared with this amplifier. With distortion levels as low as they are in the Universal Tiger, speaker, cartridge, and tuner distortion will have to be reduced by a factor of at least ten to make the amplifier distortion a significant contributor to overall distortion.

If you decide to build any of the high-power versions of the Universal Tiger, remember that most speaker systems are rated for *peak* power handling ability. This means that in most cases you have to divide the peak power by two to determine roughly the amount of *rms* power the speaker can tolerate without damage. Other than this, there are no precautions that have to be taken. —30—

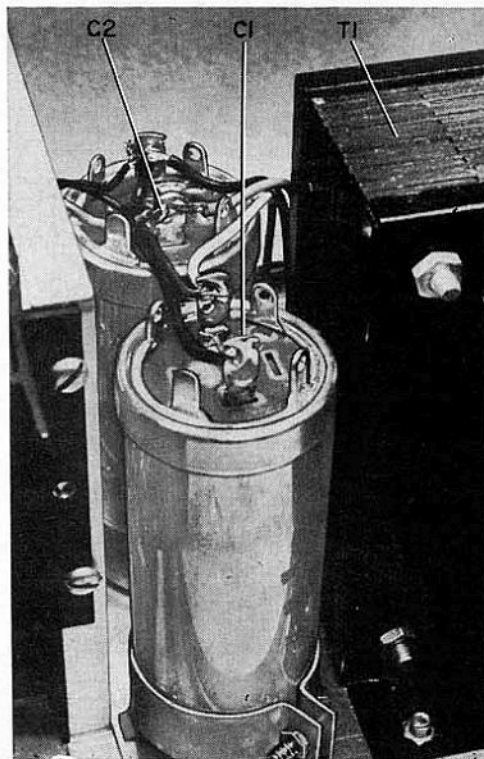

Filter capacitors C1 and C2 in power supply mount between amplifier assembly and power transformer.

