

60¢ DEC 1973

Radio-Electronics

FOR MEN WITH IDEAS IN ELECTRONICS

**ALL ABOUT CMOS
Micropower IC's**

**REGULATED IC POWER SUPPLIES
How To Design Your Own**

**NEW COLOR TV CIRCUITS
'74 Sets Are Different**

**TWO NEW SPEAKER SYSTEMS
For Great Hi-Fi Sound**

**USING THE VECTORSCOPE
10 New Applications**

**BUILD TIGERSAURUS
250-Watt Hi-Fi Amplifier**

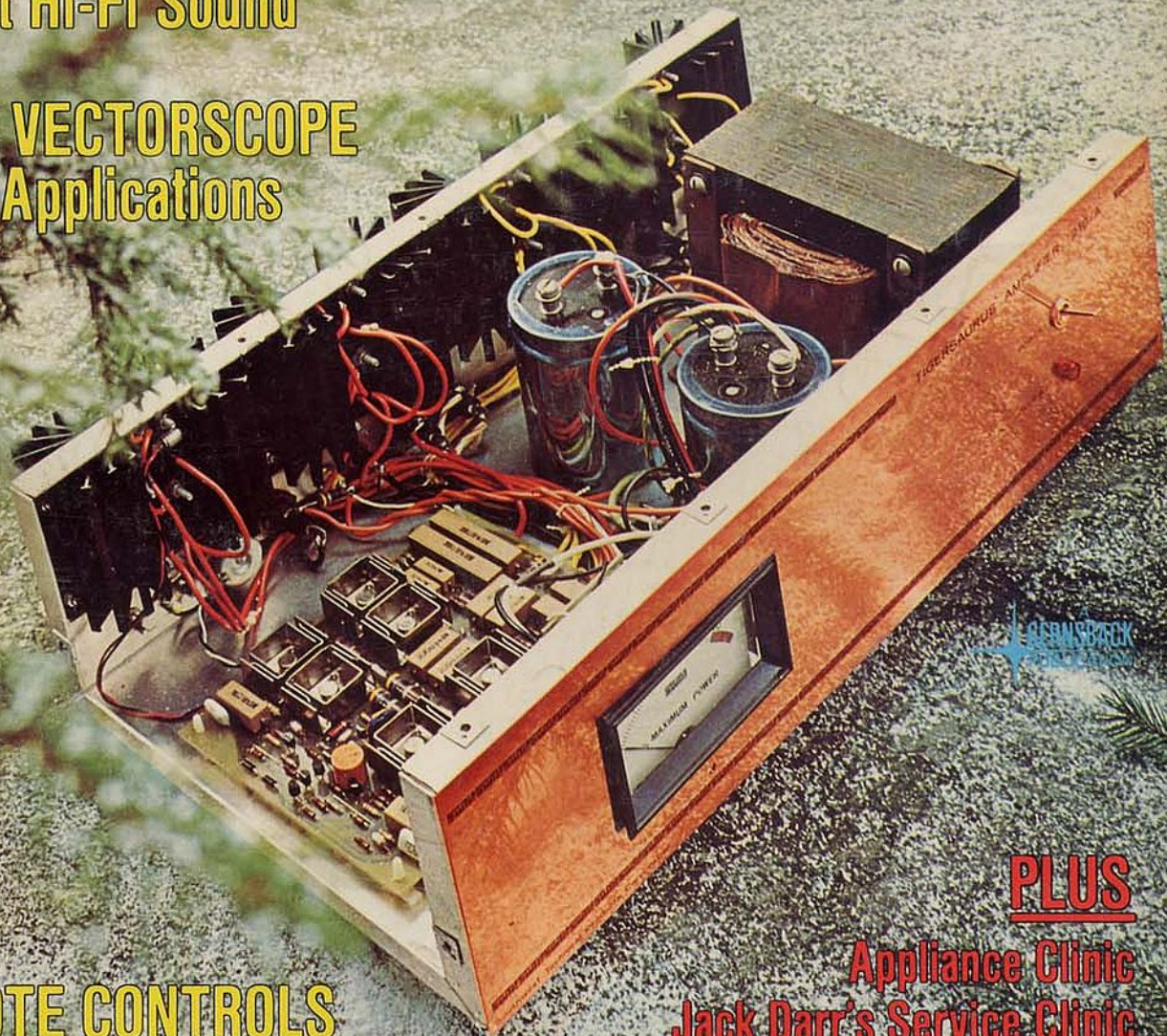

**TV REMOTE CONTROLS
Something New For '74**

PLUS
Appliance Clinic
Jack Darr's Service Clinic
R-E's Replacement Transistor Guide

Radio-Electronics

FOR MEN WITH IDEAS IN ELECTRONICS

More than 65 years of electronics publishing

DECEMBER 1973

COLOR TELEVISION

- 37 **New Circuits For '74**
Exciting new circuits highlight the '74 sets. Here's a preview for you. *by Steve Leckerts*
- 40 **Remote Control For Color**
You'll be surprised at the new color remote features. *by Karl Savon*
- 51 **10 Ways To Use Your Vectorscope**
How to master low-level circuits and speed troubleshooting with your vectorscope. *by Robert G. Middleton*
- 61 **Service Clinic**
Off-color problems. *by Jack Darr*
- 70 **Reader Questions**
R-E's Service Editor solves reader problems.

BUILD THIS ONE

- 43 **TIGERSAURUS—250-Watt HI-FI Amplifier**
Less than 0.2% distortion at full rated output—a dream of a quality high-power amplifier. *by Dan Meyer*

SOLID-STATE ELECTRONICS

- 33 **CMOS—Why Is It So Good?**
New, micropower IC's you're going to see a lot of. Learn how they work. *by Don Lancaster*
- 54 **Design Your Own Regulated Power Supplies**
Working with the latest IC technology to come up with custom-tailored power supply circuits can be easy—once you know what to do. *by Don Lancaster*
- 58 **R-E's Transistor Replacement Guide**
165 more replacement transistors by 8 different manufacturers are presented in this issue. *by Robert & Elizabeth Scott*

HI-FI STEREO AUDIO

- 48 **Two New Hi-Fi Speaker Systems**
British Industries and Electro-Voice make news with their latest developments in quality speaker systems. *by Leonard Feldman*

GENERAL ELECTRONICS

- 4 **Looking Ahead**
Tomorrow's news today. *by David Lachenbruch*
- 26 **Appliance Clinic**
Speed controls and black boxes. *by Jack Darr*
- 57 **Annual Index**
Complete directory of all articles that appeared in **Radio-Electronics** during 1973

DEPARTMENTS

- | | | | |
|----|--------------|----|----------------|
| 95 | Books | 16 | Letters |
| 6 | New & Timely | 83 | New Literature |
| 80 | New Products | 93 | Next Month |

SEASON'S GREETINGS

The editors and staff of *Radio-Electronics* extend best wishes for the holiday season.

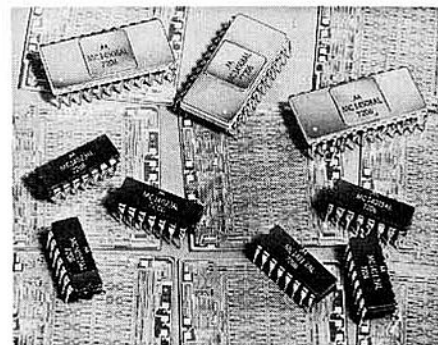

CMOS, A NEW BREED of micropower IC's. Learn how they work and see what you can do with them. . . . see page 33

Hugo Gernsback (1884-1967)
founder

M. Harvey Gernsback, editor-in-chief
and publisher

Larry Steckler, CET, editor

Robert F. Scott, W2PWG CET, technical editor

Jack Darr, CET, service editor

I. Queen, editorial associate

Leonard Feldman, contributing high-fidelity editor

David Lachenbruch, contributing editor

Barbara Schwartz, editorial assistant

Vincent P. Cienia, production manager

Sarah Martin, production assistant

H. Matysko, circulation

Arline R. Fishman, advertising coordinator

Cover photograph by Walter Herstatt

Cover design by Louis E. Rubsamen

Radio-Electronics is indexed in *Applied Science & Technology Index* and *Readers Guide to Periodical Literature*.



Radio-Electronics, December 1973, Vol. 44, No. 12. Published monthly by Gernsback Publications, Inc., 200 Park Avenue South, New York City 10003. Second-class postage paid at New York, N. Y. and additional mailing office. One-year subscription rate: U.S.A., U.S. possessions and Canada, \$7; Pan-American countries, \$8; Other countries, \$9.50. Single copies 60¢. ©1973 by Gernsback Publications, Inc. All rights reserved. Printed in U.S.A.

Subscription Service: Mail all subscription orders, changes, correspondence and Postmaster Notices of undelivered copies (Form 3579) to Radio-Electronics Subscription Service, Boulder, Colo. 80302.

A stamped self-addressed envelope must accompany all submitted manuscripts and/or artwork or photographs if their return is desired should they be rejected. We disclaim any responsibility for the loss or damage of manuscripts and/or artwork or photographs while in our possession or otherwise.

As a service to readers, **Radio-Electronics** publishes available plans or information relating to newsworthy products, techniques and scientific and technological developments. Because of possible variances in the quality and condition of materials and workmanship used by readers, **Radio-Electronics** disclaims any responsibility for the safe and proper functioning of reader-built projects based upon or from plans or information published in this magazine.

TIGERSAURUS

build this 250-watt HI-FI amplifier

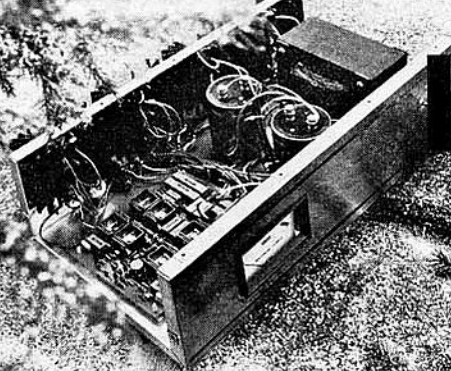

If you really need lots of power to get ear-splitting volume from an inefficient speaker system or sound for the local stadium, Tigersaurus may be for you.

by DANIEL MEYER

IF YOU OWN ONE OF THE NEW VERY low efficiency speaker systems, that requires enough power to run a small car; or if you must provide sound in a really large area then Tigersaurus "250" should interest you. True to its name this amplifier produces beastly amounts of power. Power output is rated at a conservative 200 watts into an 8.0 ohm load and 250 watts into a 4.0 ohm load. Typical output at clipping is over 300 watts. A check of the specifications will confirm that Tigersaurus is also equal to, or better in performance than other amplifiers in this power class. The circuit features the same push-pull cross-coupled complementary system used in the Tiger .01 (*Radio-Electronics*, March-April, 1973). Volt-amp limiting type protection in the very robust output stage, with generous heat sinking per channel insures safe operation at any level. Chassis layout is clean and open, so construction is not tricky in any way. If you have always wanted to build a really BIG amplifier, Tigersaurus is for you.

The input circuit in this amplifier is nearly the same as that used in "Tiger .01". Figure 1 shows the basic input system used in these amplifiers. A complementary differential amplifier makes the amplifier push-pull from the input all the way through to the output. The emitters of the differential amplifier pairs are supplied current from a high-impedance current source. This, plus the Zener stabilized supply voltage used for the first two stages in-

sure a very high degree of isolation from any hum, or noise on the supply lines.

Since the critical stages are regulated and isolated so well any type fancy regulation in the power supply is a waste. The supply can consist of a simple rectifier and capacitance filter. A 25-amp bridge is used for the rectifier to insure minimum loss at this point, while large 10,000- μ F filters hold ripple down as much as possible at full power operation.

The second stage amplifiers Q4 and Q8 (Fig. 2) provide a current drive voltage to the output stages. Since the output stage operates at a gain of approximately four, emitter resistors for Q4 and Q8 can be made large enough to insure excellent stability in this stage. If the output configuration required a driving voltage equal to the sum of the supply voltages, as is often the case in quasi-complementary output circuits, the driving system would have to be operated at a higher voltage than the output stage, or a less desirable driver system of some type would have to be used. *Only* when the output stage is designed with some gain can you use a lower voltage on the drivers.

The lower driving voltage also is helpful in reducing problems with collector capacity that occur when very large voltage swings are required from the driver. Bias for the output stage is provided by the emitter-to-collector voltage drop of Q9. This voltage is set by trimmer R22. Diode D4 is physi-

cally mounted on the heat sink and changes in its voltage drop with heat sink temperature correct the bias voltage as the output stages change operating temperature. Q10 and Q11 are drivers for the output power transistors. In an output stage of this type having more than unity gain, you must use complementary output and driver stages.

There is no way to build this type output section with one polarity of power transistor. This somewhat limits your choice of output transistors to either single diffused, or epitaxial base power transistors. High-voltage triple-diffused power transistors are simply not made with pnp polarity. If you insist on using this type transistor then you are also committed automatically to a quasi-complementary system, high drive voltage, etc. even though you might not choose to do things this way.

Since single-diffused transistors are too slow to be considered for a wide-band amplifier, the only real choice is between the various epitaxial types. You can either use a high-voltage type, or stack lower voltage types to get the necessary voltage rating to handle the desired power. A quick look at the available transistors shows that you will have the same number of devices using either type, provided you want at least a 140-volt 30-amp output rating. Since the lower voltage, higher current types cost much less and since they also have a superior F_t , it should not take anyone more than a

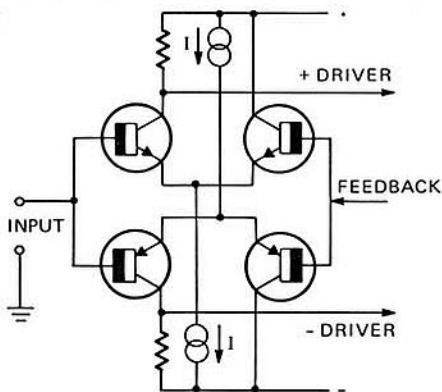

FIG. 1—BASIC INPUT CIRCUIT in a complementary differential amplifier with the emitters fed from constant-current sources.

few microseconds to make a choice.

The output stage then consists of a driven transistor and a slave stage whose only function is to sop up half of the voltage drop across the output stage and prevent exceeding the V_{ce} rating of any of the transistors. The two slave stages are Q16 and Q18 on the positive side and Q21 and Q23 on the negative side of the supply. They are driven by Q12 and Q13 respectively. Q12 and Q13 are biased at approximately half supply voltage by the

resistors in their base circuit that connect from the output point to the two supply voltages.

Thus when the output has a signal voltage present the slave stages have one half of the supply voltage plus the signal swing present dropped across them. When the amplifier is driven to full output the slave stage and the driven stage divide up the total peak voltage of approximately 130 volts so that only 65 volts appears across either transistor. This gives a generous safety margin with the 90-volt output transistors that are used in this circuit.

The output transistors are paralleled with a total of eight being used in the output stage. This provides the amplifier with an output system having a 180-volt, 60-amp rating. Although this is far more than needed to give us 200 watts into an 8.0-ohm resistor, it is necessary if the transistors are to be reasonably safe from failure when driving a reactive load. It also makes it possible for the amplifier to provide clean power into a quite reactive load that would otherwise trip the protection circuits and cause distortion.

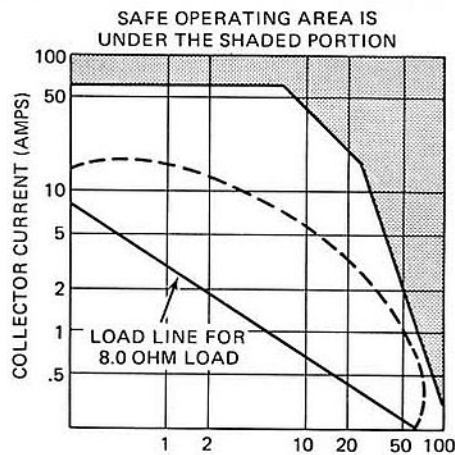
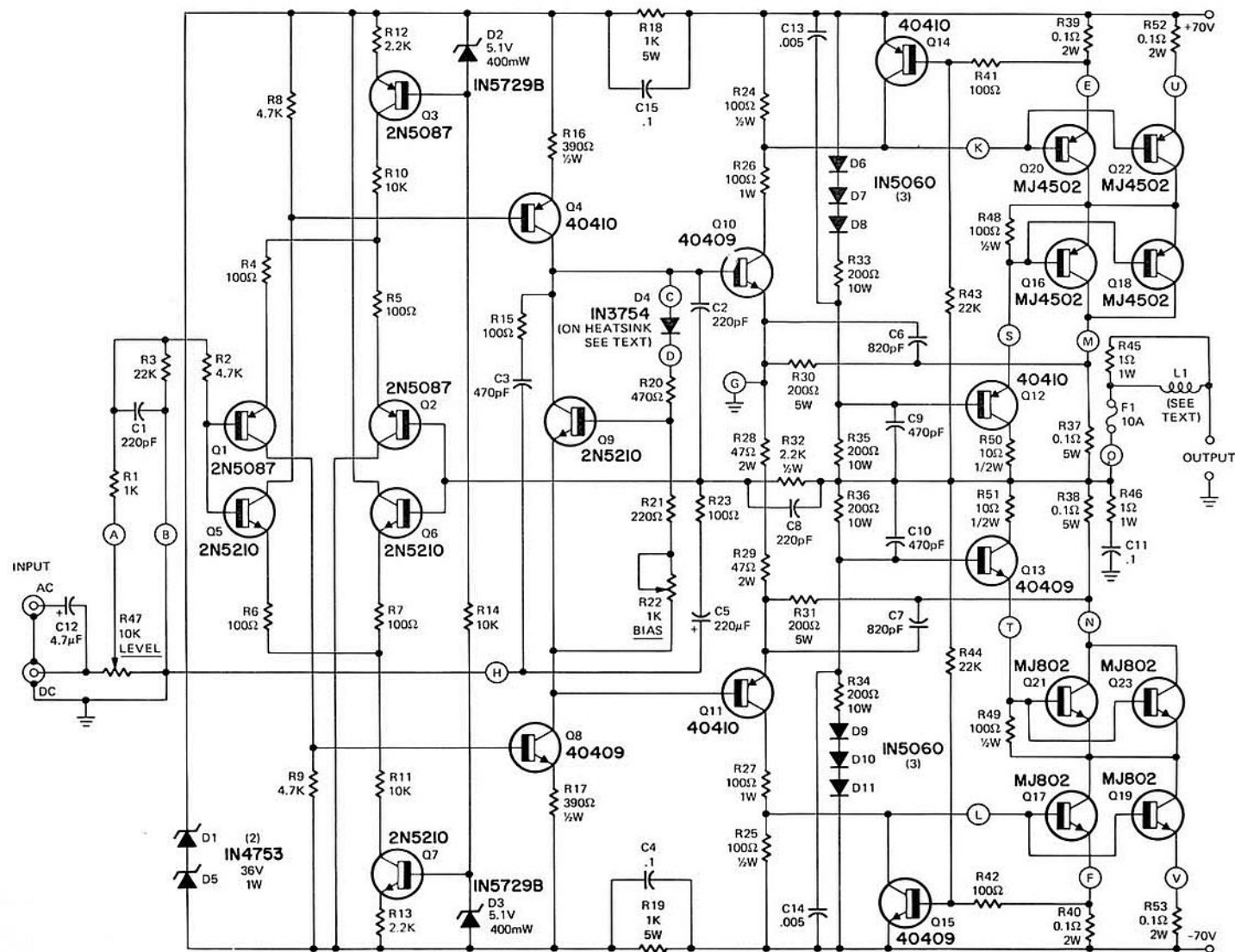

FIG. 3—RESISTIVE LOAD LINE is straight and becomes oval as reactance is added. Curve should not enter into shaded area.

FIG. 2—COMPLETE SCHEMATIC of the amplifier. Single-ended input to Q1 and Q5 develops a push-pull signal all the way to the output.

Many present day speakers become quite reactive at the resonant point on the low end and at frequencies over 10,000 Hz, so this is not a minor consideration. It is quite possible to make a high power amplifier

FIG. 2—COMPLETE SCHEMATIC of the amplifier. Single-ended input to Q1 and Q5 develops a push-pull signal all the way to the output.



PARTS LIST

All resistors 1/4-watt 10% unless noted

- R1—1000 ohms
- R2, R8, R9—4700 ohms
- R3, R43, R44—22,000 ohms
- R4, R5, R6, R7, R15, R23, R41, R42—100 ohms
- R10, R11, R14—10,000 ohms
- R12, R13—2200 ohms
- R16, R17—390 ohms, 1/2W
- R18, R19—1000 ohms, 5W
- R20—470 ohms
- R21—220 ohms
- R22—1000 ohms, trimmer
- R24, R25, R48, R49—100 ohms, 1/2W
- R26, R27—1000 ohms, 1W
- R28, R29—47 ohms, 2W
- R30, R31—200 ohms, 5W
- R32—2200 ohms, 1/2W
- R33, R34, R35, R36—200 ohms, 10W
- R37, R38—0.1 ohm, 5W
- R39, R40, R52, R53—0.1 ohm, 2W
- R45, R46—1 ohm, 1W
- R47—10,000 ohms, linear taper potentiometer
- R50, R51—10 ohms, 1/2W
- C1, C2, C8—220-pF polystyrene
- C3—470-pF polystyrene
- C4, C11, C15—0.1-μF
- C5—220-μF electrolytic
- C6, C7—820-pF polystyrene
- C9, C10—470-pF disc
- C12—4.7-μF tantalum
- C13, C14—0.005-μF disc
- D1, D5—1N4753; 36-volt, 1W Zener
- D2, D3—1N5729B; 5.1-volt, 400-mW Zener
- D4—1N3754; temperature compensating
- D6 thru D11—1N5060; silicon
- Q1, Q2, Q3—2N5087 silicon
- Q4, Q11, Q12, Q14—40410 silicon
- Q5, Q6, Q7, Q9—2N5210 silicon
- Q8, Q10, Q13, Q15—40409 silicon
- Q16, Q18, Q20, Q22—MJ4502 silicon
- Q17, Q19, Q21, Q23—MJ802 silicon
- F1—10A
- L1—6 turns of No. 16 insulated wire wrapped on the body of a power supply filter capacitor.

FIG. 4 (bottom)—FULL-SIZE PATTERN for the amplifier circuit board. FIG. 5 (below)—LOCATION OF PARTS ON THE CIRCUIT BOARD. The MJ4502 and MJ802 power transistors are on heatsinks mounted on each side of the rear of the chassis as described in text.

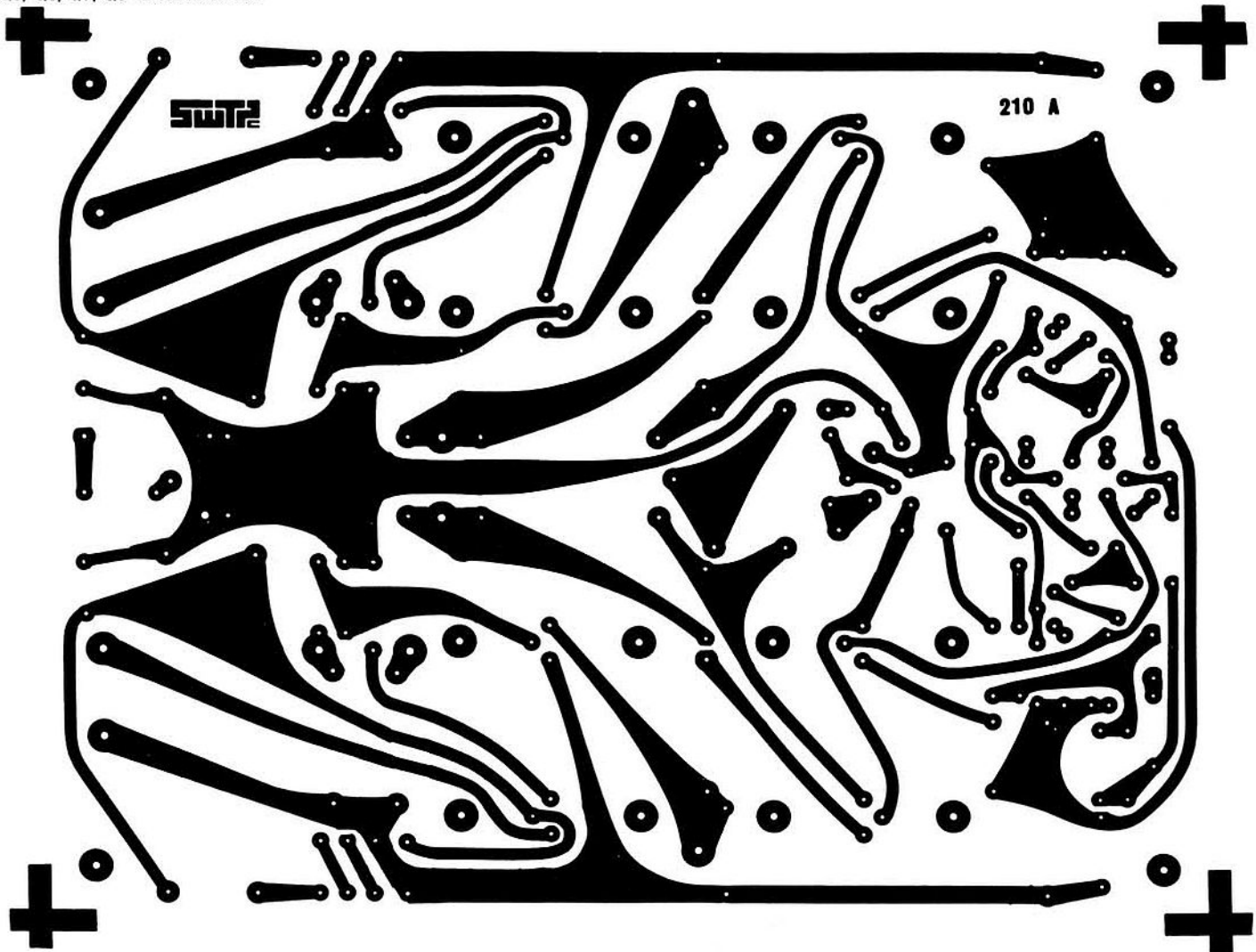
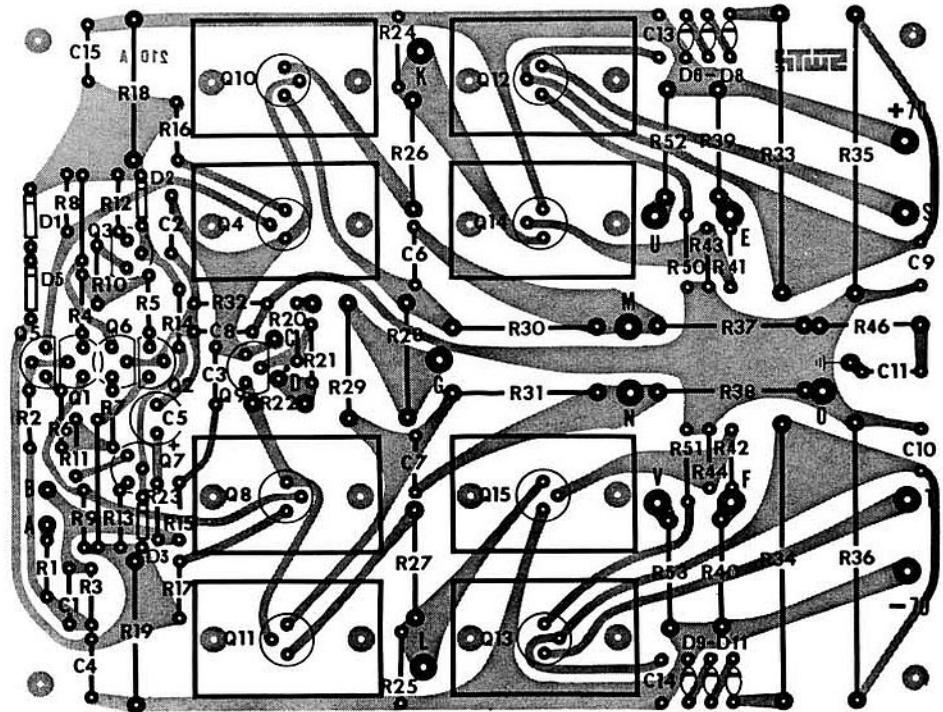

which tests beautifully on a resistive load, but which cannot provide enough power into a slightly reactive load to match much lower rated amplifiers. Figure 3 shows the resistive load line of the Tigersaurus "250" and the dc safe operating areas of the output stage. If the load becomes reactive then the load line becomes elliptical as indicated by the dashed line. As you can see, in this case there is considerable margin for operation into a reactive load before the boundaries of the safe operating area are exceeded.

In a properly designed amplifier the protection circuits will prevent operation outside the safe areas, but although this will prevent destruction of the output transistors, it does cause distortion when the protection circuits are put into operation. A rough check of the amount of useful power that can be expected from a transistor power amplifier can be made by determining how much current can be safely drawn by the transistors when subjected to peak output voltage. For equal power output ratings, the one with the largest current rating at peak voltage swing will be the amplifier with the best margins for reactive loads. It will be less likely to introduce curious little distortions when driven hard. You will not be faced with the decision of either having distortion, or getting the power.

The protection circuit in Tigersaurus consists of transistors Q14 and Q15. These transistors monitor the current through the emitter resistors R39 and R40 and also the voltage level at the output of the amplifier. If the current, or the voltage, or a combination of voltage and current exists that would cause the output stage to operate outside the safe operating area for this device the protection transistor goes into conduction and bypasses enough of the drive current going into the base of the driven output transistor to keep operation within the desired safe area.

The protection transistors can operate almost instantly since there are no capacitors to charge, or other reactances in the protection system. They clamp the output cleanly and with no bursts of oscillation when they go into operation. This is possible because the design of the output stage provides limiting resistance automatically for both the driver and the protection transistor. Resistors R28 and R26 on the positive side of the circuit and R27 and R29 on the negative side limit the maximum driver current to slightly more than 1 amp under any conditions. The less gain enclosed by the protection circuit loop, the less chance for oscillation and the more gradual will be the transition into the clamped, protection mode of opera-

tion. This more gradual clamping action produces fewer distortion products and is a bit less obnoxious in its effect than sudden sharp clamping action.

Phase compensation of the amplifiers response is provided by C1, C2, C3, C8 and C11 in combination with R1, R15 and R46. This controls the high frequency gain of the amplifier and insures stable operation with the negative feedback loop connected. The metering circuit (Fig. 6) is well isolated from the amplifier output by the resistor in series with the meter rectifier, and has no effect on performance. The meter is calibrated to read in percent of full output.

Construction is quite straightforward. The full size circuit board pattern (Fig. 4) and parts location (Fig. 5) help keep it simple. The heat

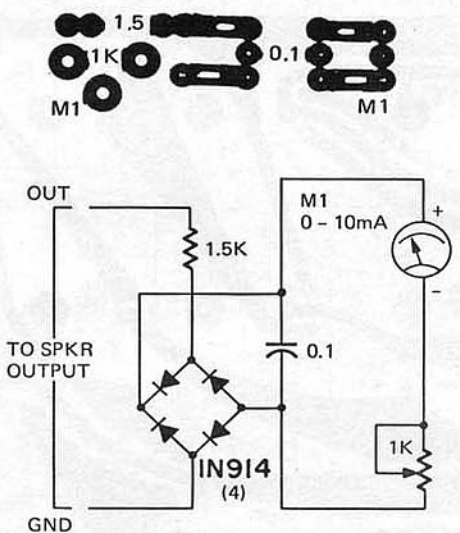
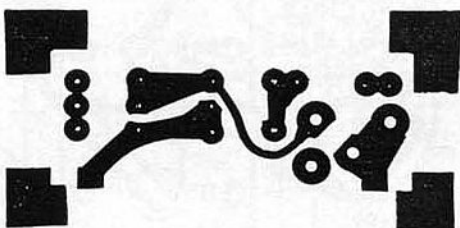

FIG. 6—THE METERING CIRCUIT PC board pattern with the schematic diagram below. Meter reads percent of full output.

sinks (8 of them) are "Wakefield" type 641K drilled so that they may be mounted back-to-back on each side of the rear of the chassis. Two transistors are mounted on each heat sink and are insulated from the heat sink with mica washers. Base and emitter pin connections may be soldered, or pin connectors may be used if desired. The connection from point O to the output jacks must be made with at least a 20-gage wire, since up to 12 amps can flow through this circuit. L1

is formed by winding the wire around the bottom of the filter capacitor can nearest the rear of the chassis five times.

The only connection to the chassis should be at the input ground. All other grounds should be made to a heavy bus wire connecting the common sides of the two filter capacitors. These include the output ground jack, point G, etc. This will insure that you will have no hum producing ground loops, or oscillation producing common impedances.

After construction is completed, the circuit should be tested in stages to insure that any problems, or errors are found and corrected before they can do serious damage. Test the power supply first (Fig. 7). Disconnect the +70 and -70-volt circuits from the amplifier and measure from each filter capacitor terminal to common. The meter should show an initial low reading which should increase as the filters charge.

If this looks okay, plug the line cord in and measure the voltage at the filters. You should have approximately +75 and -75 volts dc. If this is right pull the plug and allow the filters to discharge, or discharge them by putting a 1k resistor across each one for a few seconds. Now connect the supply to the amplifiers circuit board. Leave the power transistors disconnected. DO NOT connect points K, L, T or S; or either supply voltage to the output stage as yet.

Turn trimmer R22 to maximum resistance and apply power to the board. First measure the voltage at point O. It should be no more than +1V, or -1V. Now measure the voltage across (not to ground) R24 and R25. You should have less than 0.6 volt across either resistor. If you have a large reading on either one, or both

SPECIFICATIONS—TIGERSAURUS "250"

- Power Output—200 watts 8.0-ohm load
- 250 watts 4.0-ohm load
- 300 watts typical at clipping
- Distortion—Less than 0.2% up to full rated output
- Frequency Response—3 dB down at 5 Hz and 400,000 Hz
- Hum and Noise—more than 90 dB below full output.
- Sensitivity—2.0 volts rms in for full 250-watt output
- Damping Factor—Greater than 100 with 8.0-ohm load, 20-20,000 Hz.
- Size—17½ x 10¼ x 5 inches
- Weight—28 lbs
- Power Required—120 Vac @ 5 amps or 240 Vac @ 2.5 amps

check for problems in the bias system. Typical would be a reversed D4. If bias voltage from base to emitter of Q9 is normal—not over 1.5 volts dc—check for missing ground connections at the input point **B**, or at point **G**, or possibly between the supply common and the input jack.

Once you have normal operation to this point, check points **S** and **T** for +37 and -37 volts respectively. If all of this looks normal take a deep breath and connect your output stage. Double check to be sure you don't have shorts from any case to the chassis. *Be absolutely sure that all wiring is as shown in the schematic. A mistake*

here can cost you eight rather expensive output transistors. \$40 to \$50 worth of parts is nothing to be careless with.

If you are not the "hero" type you might want to put a 1k limiting resistor in series with R39, R40, R52 and R53 the first time you apply power to the complete circuit. These will possibly prevent disaster if all is not well after all. Once you have the limiting resistors in place, apply power to the amplifier and quickly measure the voltage drop across the added 1k resistors. It should be less than 5.0 volts and in most cases will be near zero if operation is normal. You should be able to increase the voltage

across the resistors by advancing the bias trimmer.

Now remove the resistors and connect the emitters directly to points **E**, **F**, **U** and **V**. Put the bias trimmer back at maximum resistance. Turn the amplifier "on" and check for a near zero dc reading across the output jacks. If you get any reading on the output meter, you have oscillation problems and should turn the amplifier off as quickly as possible.

If everything looks "go" connect an oscillator and a load resistor. Turn the level control up until you get a 40-volt rms output at 1,000 cycles across that 8.0-ohm load resistor. Turn the calibration trimmer on the meter to get a reading of 100%. Now reduce the output to something in the order of 2 or 3 volts rms and switch the oscillator to 10,000 cycles. Adjust the bias control for a smooth crossover. Don't overdo it, or your idle current will be excessive. This adjustment may also be made more exactly with an IM analyzer if you have one, or can get the use of one. Just set the control for minimum IM at an output level of 1 to 3 watts. Stop when the reading will not drop any further with continued rotation of the bias trimmer.

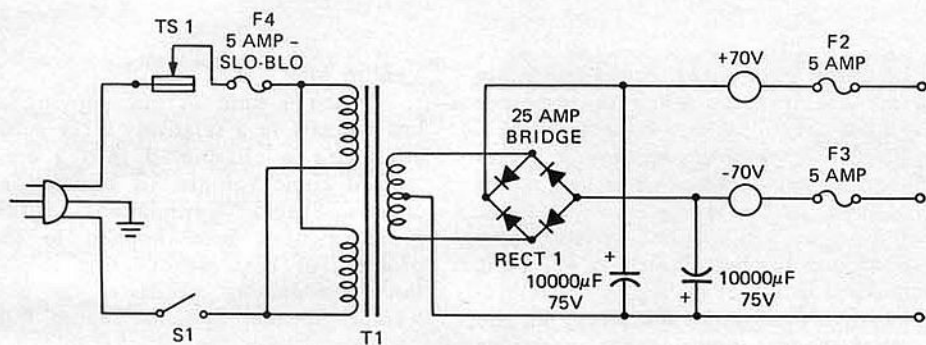
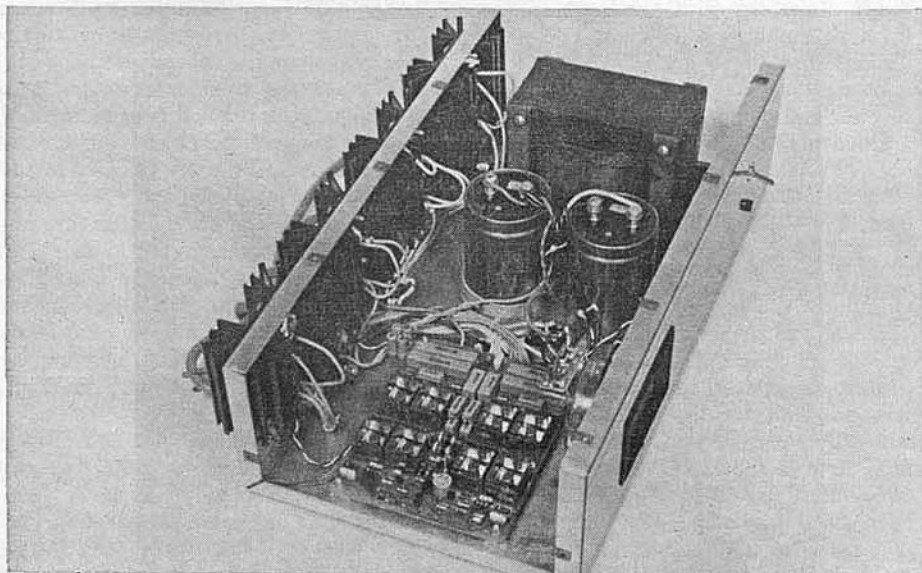
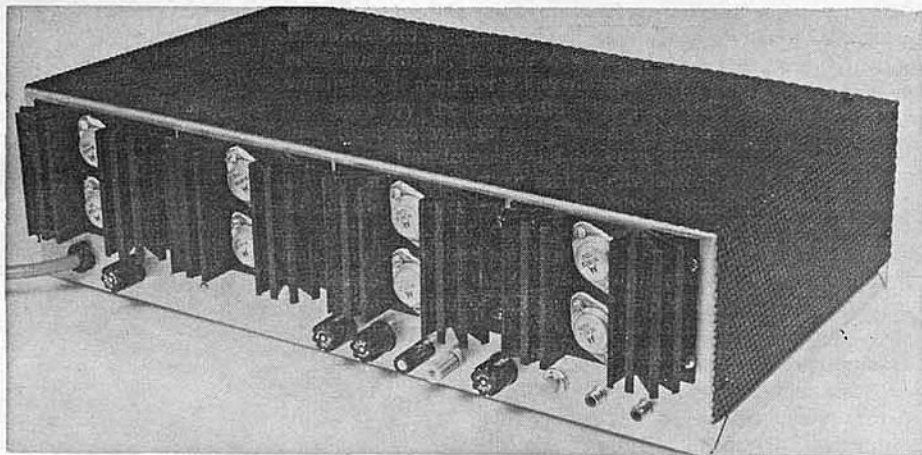

FIG. 7—POWER SUPPLY CIRCUIT. The power transformer shown has dual primary windings for use on both 120- and 240-volt ac lines. Positive and negative voltages are supplied.



The following parts are available from Southwest Technical Products, 219 West Rhapsody, San Antonio, Texas 78216.

Circuit board; etched and drilled. \$5.50 postpaid.

Power Transformer. \$30 plus postage and insurance (22 pounds).

Complete kit of all parts. \$150 plus postage and insurance (28 pounds)

THE TWO PHOTOS on the left show the rear and interior of Tigersaurus. Note that each of the power transistor heat sinks consists of two assemblies bolted back to back. If you skimp on these heat sinks the power transistors will overheat and burn out.

NOISE IN GE "PORTA-FI"

They brought in a GE receiver unit, and called it a "Porta-Fi". Works with a big console stereo, and picks up the music, etc. Never ran into one before.

Anyhow, it works, but it's very noisy. Has a loud harsh buzz. Turn volume down, no buzz. I'm puzzled.—J.M., Donora, Pa.

Un-puzzle. This is a "carrier-current" device, like a wireless intercom. The transmitter, in the console, generates a low-frequency rf signal, which is carried to the receiver over the ac power lines. Works on one of two channels, 250 or 300 kHz.

Your buzz could easily be unfiltered fluorescent lights, or SCR light dimmers, etc. Turn them off and see if this stops the noise. If so, filter *them*, not the receiver unit.

Alternative: the receiver unit may not be correctly tuned to the transmitter. Normally, the receiver should "quiet" with a strong carrier.

SOUTHWEST TECHNICAL PRODUCTS CORPORATION

219 W. RHAPSODY
SAN ANTONIO, TEXAS 78216
PHONE: 512 DI 4-3140

December, 1973

Dear Radio-Electronics Readers,

One of the most popular kits we have ever offered is our bench power supply shown at the right. Our philosophy on this project was to make as rugged and high capacity a power supply as possible with both voltage and current meters on the panel. Regulation was to be a secondary consideration. Our thoughts here were that in most cases where a supply is used, what is really wanted is all the voltage and current capacity possible for the money. In most applications it really



makes little difference if the thing regulates .00% or 1%. Think about that for a minute. When was the last time you really needed a power supply with .01% regulation? Maybe never, eh? It is very nice to be able to observe the output voltage and the amount of current drain at the same time while using a bench supply. It is all too easy to have something not work right and draw excessive current. If you have a supply with only one meter that does double duty and reads both current and amps with the flip of a switch, the thing will always be set on volts when you get an overload, or a short and draw excessive current. This basic law of nature, (the Edsel-Murphey Law) almost never fails. Besides the dual meters, you get from 0 to 35 Volts output and 0 to 2 Amps current. Voltage and maximum current are continuously variable with the front panel controls. You are not faced with the choice of two current limiting points—switch selected—as featured on some supplies. If you will check other power supply kits on the market, you will find that you can pay up to twice our price for a supply with only half the current output. Besides that, it most likely will only have one meter. Yes indeed, it may have better than 1% regulation, but you will have to decide how important that feature is to you. For only \$39.50 and 8.0 lbs. postage we can fix you up with one of these. Just ask for our # 143.

If you are doing alot of experiments with IC's and particularly operational amplifiers, you probably have run into the need for a split voltage power supply. Our new #243 is just the thing for these applications. It has a 0 to ± 20 Volt output at up to 1.0 Amp. This covers all the popular supply voltages and will provide enough current to run small power amplifiers. Price and weight is the same as our # 143.

Both supplies come in all metal cases with an attractive black vinyl covered top and a brushed gold finished front panel. The parts, circuit board, etc. are our usual first quality parts.

I would like to wish all of you a Merry Christmas and a Happy New Year.

Sincerely,

Dan

Daniel Meyer

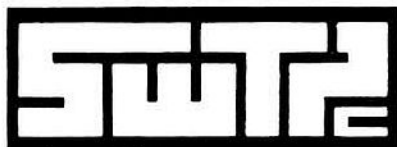

SOUTHWEST TECHNICAL PRODUCTS CORPORATION
DEPT. RE-L
219 W. RHAPSODY, SAN ANTONIO, TEXAS 78216